

Simplex[®] 5 Star SOUNDHEAD

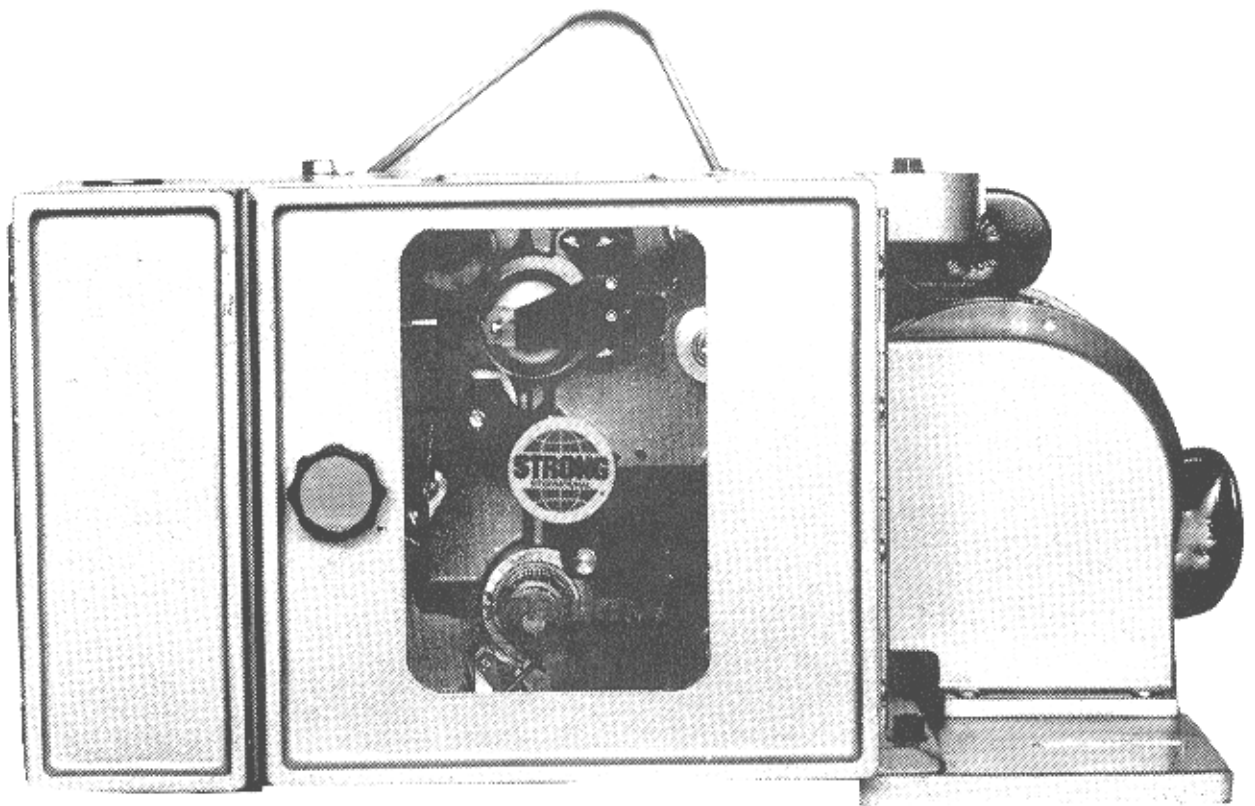

STRONG
INTERNATIONAL, INC.
4350 McKinley St.
Omaha, Nebraska 68112
402/453-4444

SIMPLEX 5 STAR SOUNDHEAD
Operating Instructions & Parts List

Section I

	Page
Description	1-1
Installation	1-3
Adjustments	1-5
Replacement Parts, Reverse Scan	1-14

Section II

Main Assembly	2-1
Soundhead Component Layout & Mounting	2-3
Slit Lens & Mount (G-1974)	2-4
Lateral Guide Roller Assembly (G-1977)	2-5
Loop Damper Assembly (G-4635)	2-6
Pad Roller Assembly (G-4643)	2-7
Exciter Lamp Bracket Assembly (G-2078)	2-8
Exciter Lamp Base Assembly (G-2080)	2-9
Door Assembly, Rear Compartment (G-4696)	2-10
Flywheel, Bushing, & Pulley Assembly	2-11
Impedance Drum Assembly (G-6754)	2-12
Sprocket Shaft Assembly (G-6753)	2-13
Idler Roller Assembly (G-6506)	2-14
Door Assembly, Film Compartment (G-6102)	2-15
Solar Cell & Bracket Assembly	2-16
Induction Drive Motor & Mount Assembly (G-7209)	2-17
Synchronous Drive Motor & Mount Assembly	2-18
Reverse Scan Components (Infrared L.E.D.)	2-20
Kelmar Reverse Scan Components	2-22
Soundhead Pulleys	2-26

STRONG INTERNATIONAL

a division of Ballantyne of Omaha, Inc.

Engineering/Sales

March 1999

Simplex[®] 5 Star SOUNDHEAD

THE SOUNDHEAD MECHANISM is contained in an assembly of aluminum castings approximately (12) inches long by (11-3/4) inches deep by (9-1/2) inches high. A 1/4 horsepower synchronous drive motor is mounted outside these dimensions. Weight (including motor) is 70 pounds.

THE OPERATING SIDE of the soundhead is enclosed by (2) doors. An (8-3/4 x 8-1/2) inch door covers the film compartment, and a (3-1/4 x 8-1/2) inch door provides access to the exciter lamp compartment. The drive mechanism belts and pulleys are accessible by removing a rear cover casting mounted to the main frame by (3) captive screws.

THE PRINCIPAL FUNCTIONING ELEMENTS of the soundhead consist of the motor, the drive mechanism, the pressure roller and impedance drum, and the motion damping mechanism. Optical elements on direct scan models include an incandescent exciter lamp, slit lens, and the solar cell(s); mono or stereo. Reverse scan soundheads utilize a visible-red L.E.D. as an exciter, and optics and signal pick-ups as required by configuration (analog or digital).

THE SYNCHRONOUS DRIVE MOTOR uses metric timing belts and pulleys in operation. The gear ratio of the pulleys reduces the 1800 rpm motor speed to the film sprocket speed of 360 rpm. The (16) tooth soundhead sprocket drives film at (24) frames per second. The sprocket shaft also carries a projector drive pulley to match film speeds between the projector and soundhead. An optional V-belt pulley, between the timing belt pulleys, supplies power take-off to drive a take-up magazine.

THE FILM is delivered continuously to the soundhead by the holdback sprocket of the projector. The film passes slack from the projector sprocket to the impedance drum. It is held against the impedance drum by a retractable felt pressure roller which is flanged to control the lateral position of the film. Through friction, the film rotates the pressure roller and the impedance drum and flywheel. After leaving the impedance drum, the film passes over an idler roller, to a damper roller, and then to the film sprocket of the soundhead. From this sprocket, the film leaves the soundhead. One and one half ounces of film tension is maintained between the impedance drum and the film sprocket. This tension is applied by a silicon fluid-damped and spring-actuated damper roller. The damper roller, in conjunction with the impedance drum, damps the hunting tendency of the mechanism at start-up, and absorbs variations in the film drive, thus minimizing the "wow" content of the sound system. "Flutter" is kept low by the impedance drum flywheel and the spring characteristics of the film as it passes over the idler and damper rollers. Two pad rollers minimize the possibility that the film sprocket will skip film perforations. The distance along the film from the picture aperture to the sound take-off point is (21) frames.

A DIRECT-SCANNING SOUNDHEAD includes an exciter lamp which illuminates a slit in the lens tube. This lens tube focuses the illuminated slit at the film plane in a pattern (.084) inches long by (.0012) inches wide. Approximately (9/16) inch beyond the film plane is a silicon solar cell. The photographic sound track of the film breaks up the light pattern on the solar cell as the film passes over the impedance drum. The solar cell converts the light information into voltage. The preamplifier supplies an amplified signal to the theatre sound system. An SVA (Stereo Variable Area) system requires a split solar cell which supplies LEFT and RIGHT channels to a stereo processor, and mounts closer to the film plane.

A REVERSE-SCANNING SOUNDHEAD utilizes an LED (Light Emitting Diode) behind the film plane to illuminate the soundtrack. All lensing, solar cells, and output terminals are included in a Signal Pick-Up Assembly mounted in front of the film plane. A Reverse Scan Soundhead requires no exciter lamp, thereby eliminating the need to periodically inspect lamp filaments and install replacement lamps.

THE PROCEDURE for threading film through the soundhead is as follows: Bring the film down from a correctly threaded projector. Retract the pressure roller and pass the film between the pressure roller and the impedance drum. Close the pressure roller against the impedance drum, making certain the film is between the lateral guide flanges. Pass the film to the right over the idler roller, approximately halfway around the idler roller and to the left over the damper roller, half around the damper roller and between the opened pad rollers and the film sprocket. Draw the film snug (damper arm pulled to its stop on the pad roller arm); back off (1) perforation, and close the pad rollers. Closing the pad rollers allows the damper arm additional rotation and allows the damper arm spring to control the film tension. From the film sprocket, direct to film to the take-up guidance roller pattern.

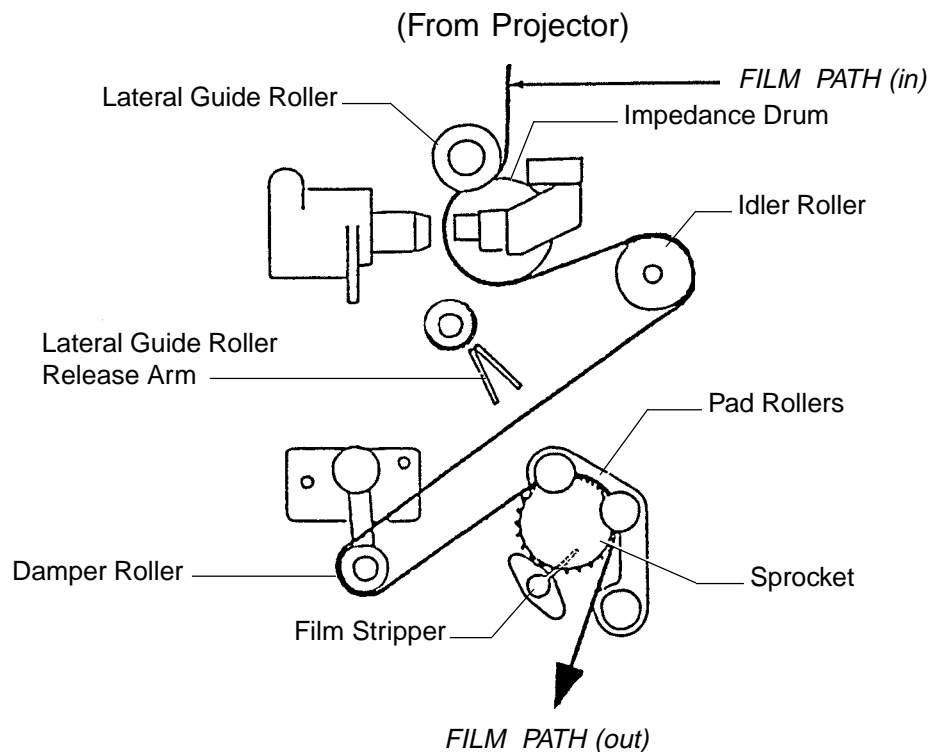

INSTALLATION

ELECTRICAL SUPPLY REQUIREMENTS:

Motor (Domestic): 115 V.AC, 60 Hz. 15 Amperes

Motor (Export): 230 V.AC, 50 Hz. 10 Amperes

Exciter Lamp (Direct Scan): 9 Volts, 4 Amperes *

L.E.D. Power Supply (Reverse Scan): 115/230 V.AC, 50/60 Hz. 3 Amperes

* The Exciter Lamp must be connected to a listed Exciter Lamp Power Supply installed and wired in conformance to local codes.

UNPACKING:

The soundhead main frame and the drive motor assembly are shipped as a unit. The main frame is secured to a shipping pallet with (2) 5/16-18 hex head screws. The impedance drum flywheel is dismantled and packed as a separate part. Mounting hardware (4 ea. 3/8-16 hex head screws, as required) are packaged separately and included in the shipping carton.

Open the shipping carton and remove the separate components. Lift the soundhead and shipping pallet from the carton. Open the access doors and remove the motor drive belt and damping fluid. Remove and discard the shipping pallet. Dismount the off-operator side cover casting.

MOUNTING:

1. Position the pedestal or console in front of the projection port before mounting the soundhead and projector. Allow not less than six (6) inches clearance between the front of the soundhead and the booth wall.
2. Insert (2) 3/8-16 mounting screws with washers into the upper two tapped holes in the rear of the main frame casting. Position the soundhead on the pedestal/console mounting arm by resting the (2) mounting screws in the upper slotted holes in the mounting arm. Insert (2) 3/8-16 mounting screws through the lower mounting arm holes and into the lower two tapped holes in the main frame casting. Tighten all (4) mounting screws securely.
3. Dismount the P-2396 Mounting Bar from the slot on the top of the soundhead casting by removing the (2) 5/16-18 hex head screws. Secure the P-2396 bar to the base of the projector using the (2) 3/8-16 socket head screws; position the open-slotted end of the bar to the rear (shutter) end of the projector.
4. Mount the projector to the top of the soundhead with the P-2396 bar in its milled slot. Secure the bar to the soundhead casting using the (2) 5/16-18 hex head screws.
5. Loosen (do not remove) the (4) hex head screws securing the motor mount to the adapter plate. Install the motor drive belt between the motor pulley and the large, inboard soundhead driven pulley. Apply tension to the drive belt by sliding the motor forward and re-tightening the (4) mounting screws.
6. Install the projector drive belt between the projector driven pulley and the outboard drive pulley on the soundhead. Apply belt tension by positioning the P-10018 Idler Pulley Bracket and P-10024 Idler Pulley (see Page 2-13) against the belt.

7. CHECK BELT TENSION. Tension should be sufficient to allow the belt cogs to firmly engage the pulley teeth, but *do not overtighten*. Excessive belt tension can damage shafts and pulleys and cause premature bearing failure.
8. Mount the P-7016 Flywheel to the impedance drum shaft and secure the set screw (see Page 2-12). Install the off-operator side cover casting.
9. Mount any required transport roller assemblies to the base of the soundhead casting using 5/16-18 screws (generally supplied by the manufacturer of the roller assembly). If a lower take-up arm or film magazine is used, an optional V-Belt Pulley (P-10021) is required between the two timing belt pulleys. Refer to the G-6753 illustration on Page 2-13.

START-UP PROCEDURES:

All necessary adjustments to the 5 Star Soundhead are made at the factory in the course of testing and run-in. It is recommended, however, to repeat all optical soundtrack scanning adjustments as a preliminary step in the installation of the sound processing equipment. These adjustments are extremely crucial for proper sound reproduction, and vibration and handling in shipping can jar components out of alignment. Qualified sound installation personnel are trained and equipped to perform these procedures.

All bearing are sealed and require no lubrication. A tube of damping fluid (P-4807) is supplied for replenishment as required. Damping fluid is applied to the G-4640 Arm by removing the P-7120 Cap (see Page 2-6).

ADJUSTMENTS

PAD ROLLERS, when closed, must allow a clearance distance of (2) thicknesses of film between the rollers and the face of the sprocket. This is accomplished by (a) setting and securing the 10-32 socket head screw (41-51213) in the pad roller arm casting (P-4624) to "stop" the lower (P-4644) shaft at the (2) thickness spacing, and (b) rotating eccentric roller shaft P-6642 to the desired spacing. See the G-4643 parts drawing on Page 2-7.

MAINTAIN correct belt tension. Tension should be sufficient to allow the belt cogs to firmly engage the pulley teeth, but *do not overtighten*. Excessive belt tension can eventually damage shafts and pulleys and cause premature bearing failure.

ADJUSTMENTS to those components relevant to scanning the optical soundtrack are best performed by qualified personnel equipped with the necessary test equipment. Attempts to effect field repairs without use of the required test equipment are generally detrimental to sound quality.

DIRECT-SCANNING SOUNDHEADS:

1. The Exciter Lamp is preset to position the filament of the lamp for maximum light output to the Slit Lens. The adjustable mounting bracket of the exciter lamp is set and locked at the factory. Replacement exciter lamps, when installed, will be correctly positioned. A remote Exciter Lamp Power Supply provides DC current to the lamp for flicker-free light output.
2. The Lateral Guide Roller directs the film path to position the soundtrack in the correct location for scanning. A Buzz Track (test film) is required for this adjustment.
3. The Slit Lens projects the image of the exciter lamp filament to the soundtrack of the film. The Azimuth and Focus of the slit lens is set and locked. These adjustments require use of 9 kHz. test film, "pink noise" test film (Dolby Cat. No. 69), a dual-trace oscilloscope, and a spectrum analyser.
4. The type and positioning of the Solar Cell is determined by the type of sound processing equipment connected to the soundhead. The solar cell collects the pulsating light pattern defined by the slit lens and converts the information into electrical current. A solar cell used with a monophonic sound system is positioned approximately 9/16" behind the film plane and outputs (1) channel. A split solar cell is used for SVA (Stereo Variable Area) sound processors. It is positioned no less than 3/16" behind the film plane, and outputs (2) channels (left and right).

REVERSE-SCANNING SOUNDHEADS:

1. The Lateral Guide Roller directs the film path to position the soundtrack in the correct position for scanning.
2. An L.E.D. (Light Emitting Diode) is positioned directly behind the film plane to illuminate the soundtrack. The horizontal position relative to the soundtrack, and the distance from the film, are set and locked. The L.E.D. is powered by a remote, low-voltage, current regulated power supply.
3. A Signal Pick-Up Assembly is mounted in front of the film plane, and contains the lensing, the solar cells, pre-amps, and terminals for the cell output. This assembly is factory-set to maximize the reception of the signal generated by the L.E.D.
4. A second L.E.D. illuminator and signal pick-up are required for scanning digital prints. These components are mounted adjacent to the analog elements, 90° off the analog axis.

Reverse-Scanning Optics, using an infrared L.E.D. (Light Emitting Diode) as a light source, were adopted by Strong International in 1995. A visible light L.E.D. replaced the infrared unit in 1997. An L.E.D. features a much longer life (15,000 hours) than an exciter lamp, and eliminates signal loss because of sagging or aging bulb filaments. The one-piece Signal Pick-Up detects only L.E.D. inputs, and stray booth lighting does not distort the solar cell output. Channel separation is enhanced by incorporating the solar cells within the sealed lens assembly. Reverse-Scanning soundheads are identified by a /SR suffix on the Equipment Type designation.

The duty cycle (time ON) of the L.E.D. should parallel that of the xenon bulb; the lamphouse elapsed hour meter should approximate L.E.D. hours. L.E.D. manufacturers have noted a 10-20% drop in light output after prolonged (10 year) operation. If a sound signal loss cannot be corrected by fader gain, it may be necessary to replace the L.E.D. Illuminator.

Traditional Direct-Scanning Optics remain available and may be specified on the original equipment order. The exciter lamp DC power supply required for use with the direct-scanning soundhead must be ordered separately; the L.E.D. power supply required for reverse-scanning optics is included with the system. Power supplies of either type are mounted and wired remotely from the soundhead.

Simplex Direct-Scanning Soundheads already in service can be readily converted to Reverse-Scanning Optics by the installation of Reverse Scan Kits:

51-98261	Reverse-Scanning Soundhead Conversion Kit, Analog
51-98258	Reverse-Scanning Soundhead Conversion Kit, Analog; Digital Convertible
51-98300	Reverse-Scanning Soundhead Conversion Kit, Analog and Digital (SR•D)

Replacement L.E.D. (light source) Heads are easily mounted to the Illuminator Bracket and may be installed upon output decrease or failure of the L.E.D.

WIRING

Install the L.E.D. Power Supply to the projection console or to a rack adjacent to the soundhead. Mounting brackets should be specified on the original equipment order; Part No. 51-06026 for Rack Mounting, 51-06030 for Console Mounting. Route the power leads to the soundhead-mounted L.E.D. Illuminator Assembly using 18 gauge wires for short runs; 16 gauge wires for excessively long runs.

Pre-amp connections to the analog Signal Pick-Up are made to the clearly-marked terminals on the back of the unit. These connections include:

<u>Power Input</u>	<u>Solar Cell Output</u>
12 V.DC +	Right Channel "HI"
12 V.DC -	Right Channel "LO"
Ground	Ground (Shield)
	Left Channel "HI"
	Left Channel "LO"

It is recommended to use (2) shielded two-conductor cables to connect the solar cell outputs, but use of a three-conductor, single-shield cable is permitted. If using three-conductor cable, strap the two "LO" terminals together. Since very little current is required, 22 gauge wire is adequate. DO NOT interconnect *input* and *output* grounds.

Digital readers utilize a visible light L.E.D. powered by the LS-30 Power Supply. Use 18 gauge hook-up wire between the L.E.D. and the LS-30 power supply. Pre-terminated digital output cables (51-98272) are supplied, and should be connected to the processor as instructed in the Dolby manual.

ALIGNMENT (Analog)

Energize the L.E.D. and test equipment to Solar Cell Output terminals. Turn the sound processor's *level* and *high frequency* adjustment to minimum settings.

Loosen, but do not remove, the socket head screw clamping the L.E.D. head to its mounting post and bracket. Loosening this screw permits moving the L.E.D. head up and down, and on the horizontal plane (in and out). Position the L.E.D. to visually locate the light directly opposite the lens opening of the Signal Pick-Up Assembly. Run a loop of level set ("Dolby Tone") film and observe the output of the LEFT and RIGHT channels. When the highest output is seen, move the L.E.D. head horizontally (in and out) in the impedance drum. DO NOT permit the L.E.D. head to touch the inside of the impedance drum. Observe the output and secure the L.E.D. head when the highest output is achieved.

Run a "Buzz Track" (SMPTE No. 35-BT) loop and set the lateral guide roller as required. It is recommended to splice together a loop of half "Buzz Track" film and half "Left/Right Alignment" (Dolby Cat. No. 97) test film. This permits centering the soundtrack and checking for cross-talk simultaneously. Set the focus and azimuth by running the "pink noise" loop and adjusting the Signal Pick-Up Assembly in the same manner as a conventional slit lens. Finalize the "A" chain installation by again checking the L.E.D. adjustment using Dolby Cat. No. 566 "illumination uniformity" test film. Perform a final "Dolby" level set, and complete any other steps specified by the manufacturer of the sound processor.

ALIGNMENT (Digital)

Perform the above procedure, but do not consider the analog installation complete until also setting the digital scanning components. In order to best accommodate the scanning of TWO soundtracks, some fine adjustments to the analog scanning will be re-set in the course of digital alignment.

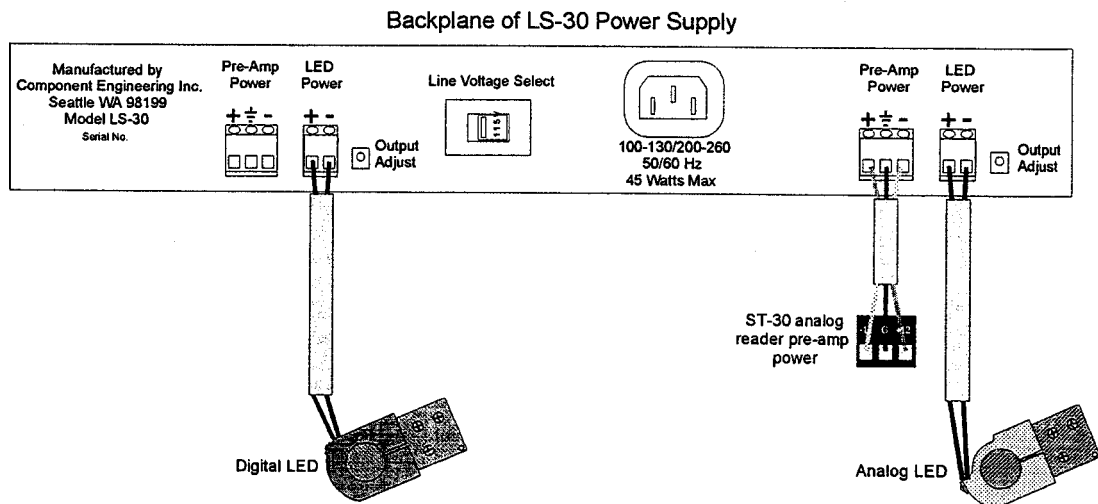

The visible L.E.D. Dual Reader is supplied with the LS-30 Modular Power Supply. The LS-30 contains (2) of the universal power supply modules. The output adjustments, however, are wired to the chassis, so the modules can be interchanged without resetting the output level.

- The left unit is factory set at 450 mA. to power the analog L.E.D. The right unit is set at 550 mA. to power the digital L.E.D.
- The L.E.D.'s are bipolar; the power supply cannot damage an L.E.D. through reversed polarity. It is safe to try reversing the polarity if you have power but no light. **Accidental connection of the L.E.D. to the pre-amp power terminals will damage the L.E.D.**
- The L.E.D. and pre-amp power wiring terminals, the output adjustments, and the AC line voltage selector switch are all located on the back plane of the LS-30 cabinet. **Carefully inspect the connections and settings before powering up the LS-30.** See the illustration on the preceding page.
- Power supply module fuses are accessible by removing the module from the chassis.
- The pre-amp power to the analog reader (Signal Pick-Up) is 12 V.DC+, ground, and 12 V.DC-. The ground must be connected at both ends as it is circuit reference zero volts.

Preliminary Adjustment

- Power up the LS-30 Power Supply and the Audio Processor.
- Observe that both L.E.D.'s emit visible light.
- Connect a dual-trace oscilloscope to the left and right test points of the processor pre-amp.
- Thread and run Dolby *Tone Test* film (Cat. No. 96t).
- Observe oscilloscope traces and "Dolby" level indicators in the processor.
- If tone is visible on both channels, set to "Dolby" level.
- If not, check L.E.D. alignment and focus the optics. Then set "Dolby" level.
- Thread and run SMPTE "Buzz" track.
- Adjust lateral guide roller as required to obtain (2) very low, equal residual signals.

Analog L.E.D. Alignment

The analog L.E.D. must be aligned before the digital.

- Turn both left and right channel pre-amp gain adjustments on your cinema processor to *full down*; if using a Dolby CP-500, turn to 50%. The goal is to have equal gain on both channels.
- Thread and run Dolby Tone Test film (Cat. No. 96t).
- View the pre-amp outputs on the oscilloscope screen.
- Rotate the L.E.D. mount assembly to reach the maximum amplitude of both traces.
- Move the assembly laterally to get both traces as high and equal as possible.
- Complete the standard "A" chain alignment.

To minimize microphonics, the L.E.D. must be very accurately aligned.

- With the power amplifiers OFF, turn the processor and monitor gains FULL UP. Select a film format and the correct projector on the processor. Run the projector with no film. Fine-adjust the L.E.D. mount rotation to a point where the sound of the projector running is not heard through the sound system. The optimal adjustment will be found between two positions where the projector vibration can be heard quite clearly. Run Dolby Tone again to give the system a final adjustment. The final result will be projector noise that is below the noise floor of the processor.
- Optionally, connect an AC millivolt meter to one of the pre-amp test points. Rotate the L.E.D. mount to achieve highest output to three decimal places on the AC millivolt meter. Careful peaking will achieve the same result.

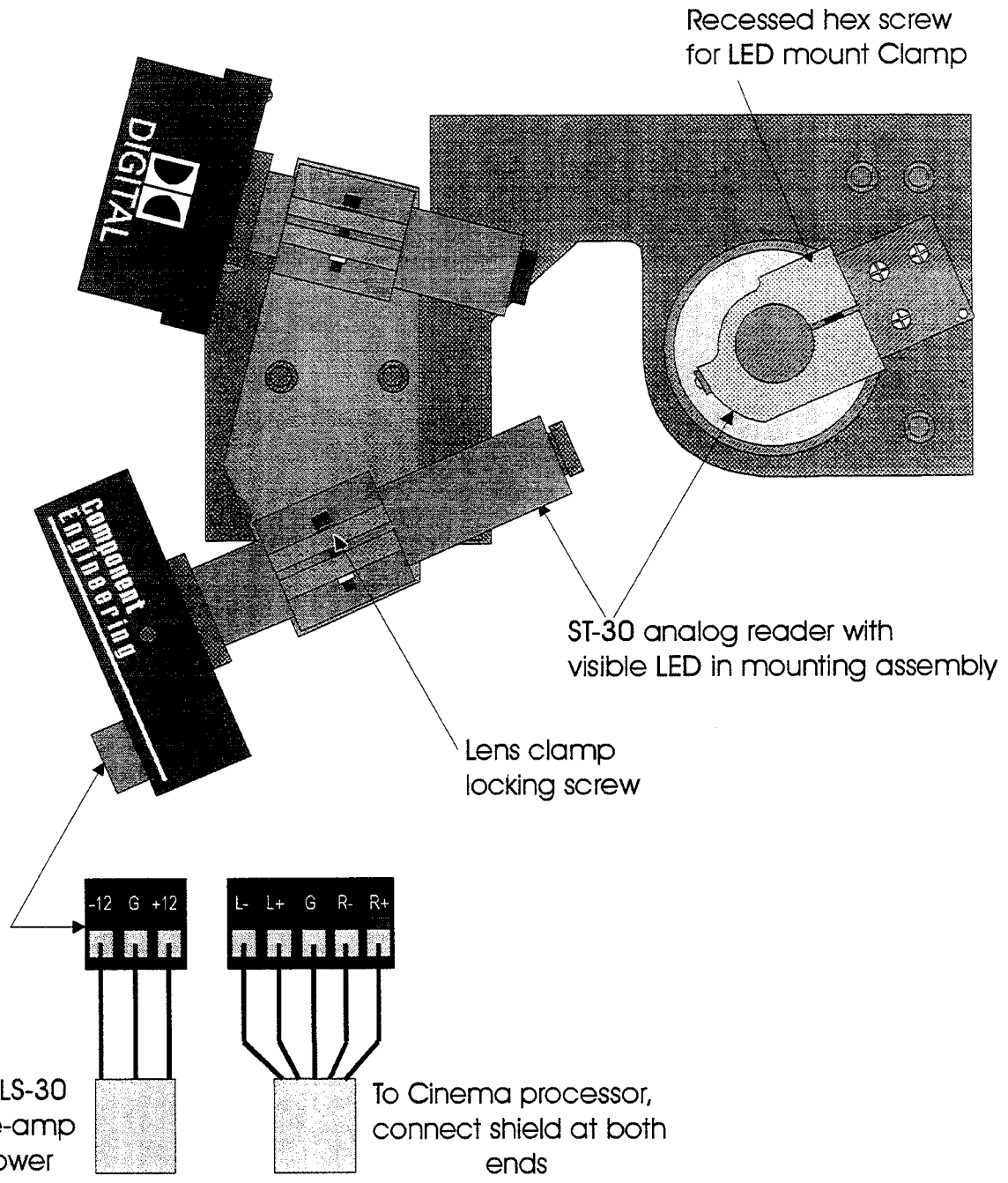

Digital Reader Alignment

- Thread and run a reel of Dolby-encoded film.
- Connect a dual-trace oscilloscope to the Dolby Digital Processor per the following instructions.
- Refer to the oscilloscope traces below in reference to the following instructions:

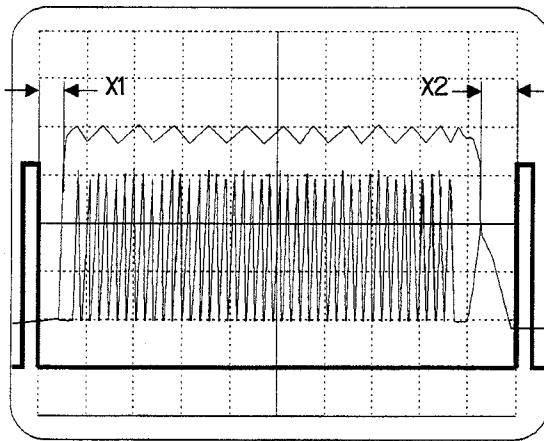

A

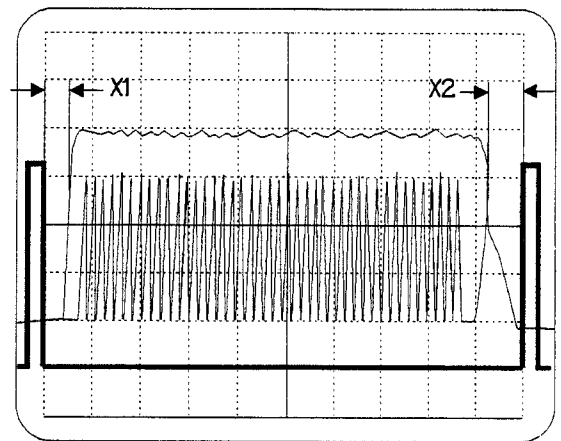

B

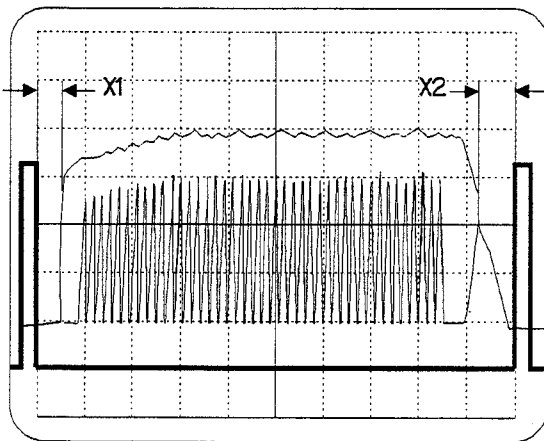

C

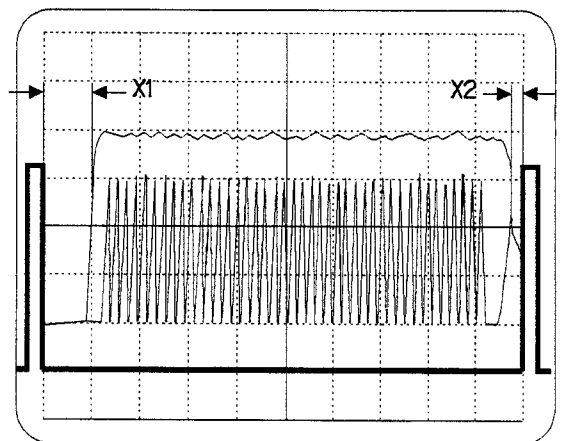

D

Figure B is in optimal alignment.

- In Figure A, the top of the sprocket hole has (12) large saw teeth. The differential between the high and low points is 1/3 volt.
- Figure B shows *more* saw teeth with *less* differential. This is obtained by fine-adjusting the rotation of the L.E.D. holder.
- In Figure C, the sprocket hole is falling off on the left, indicating uneven light. This is improved by moving the L.E.D. holder laterally until a flatter trace is obtained.
- In Figure D, the CCD board is misaligned laterally. Dimension X2 is smaller than X1. This can be improved by loosening the (2) CCD board mounting screws and moving the board until the X1 and X2 dimensions look like Figure B.

The correct alignment is off-set to the left by one minor division. That is, the sprocket hole will be 1/5 of a square off-center toward the left "goal post" on the 'scope screen.

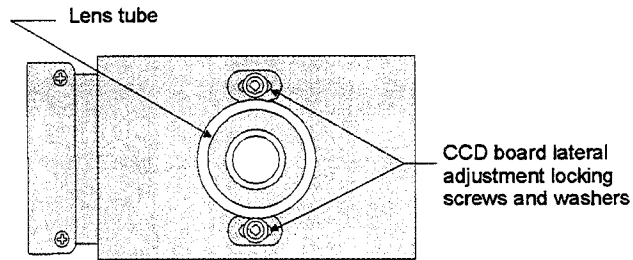

Simplex digital lens and pre-amp

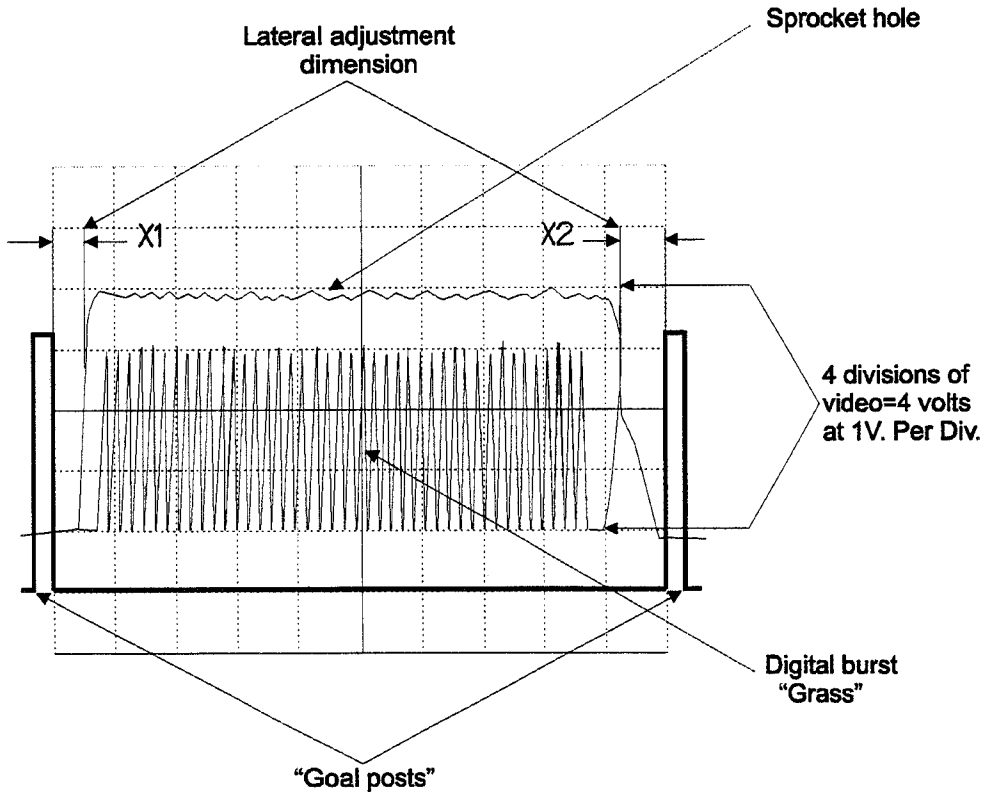

Instructions for Alignment of Readers for Dolby Digital

1. Connect a dual-trace oscilloscope to test points on Video Acquisition Card (Cat. No. 605 or 670). Oscilloscope should be 20 MHz. minimum.
 - a) Connect Channel 1 to **Video** test point; connect this probe ground only to **Gnd.** test point.
 - b) Connect Channel 2 to **Clamp** test point.
 - c) Set both channels *Volt/Div.* controls to 1 volt/div. Set vernier to calibrate. Ensure that probes are *not* at X10.
 - d) Set horizontal sweep rate to 2 usec/div.
 - e) Set trigger to channel 2 and positive polarity, adjust trigger level, and lock on signal.

2. Calibrate oscilloscope to processor:
 - a) Thread a loop of Cat. No. 69P test film into projector and reader; start machine.
 - b) Select Channel 2 for display.
 - c) Adjust the horizontal position to line up the inside edge of the left “goal post” with the left edge of the graticule.
 - d) Adjust the sweep vernier to line up the inside edge of the right “goal post” with the right edge of the graticule.
 - e) Adjust the vertical position for the baseline of the clamp signal (Channel 2) to coincide with a line in the lower section of the graticule.
 - f) Select either *Alternate* or *Chop* to give the brightest display of both channels.
 - g) Adjust the vertical position of the video signal (Channel 1) to coincide with the same line as the clamp signal.

3. Alignment of the Reader:
 - a) Loosen the lateral adjustment locking screws and roughly adjust the lateral position of the CCD board so that the outer trace (perf) is centered between the “goal posts.” This is approximate, and will be repeated later for accurate positioning. Retighten screws.
 - b) Rotate the L.E.D. mounting assembly for maximum amplitude on the upper trace without sacrificing flatness. The trace should vary one block or less ($\pm .5$ volt). As shown, Figure B is improved from Figure C. Amplitude, as measured with the top trace, should be between 2-5 volts from baseline. Adjust the digital L.E.D. for minimum ripple on the upper trace of the video signal. As shown, Figure B is improved from Figure A.
 - c) If available, use DRAS10 software and a laptop computer to view the adjustment of azimuth for a zero degree reading. Or, center the reader rotation between sync lost points using the error rate of the Digital Processor to indicate lost sync.
 - d) Adjust focus for darkest center in area of bits (grass). Confirm highest reading with DRAS.
 - e) Confirm calibration of oscilloscope as above. Readjust the lateral position to align the outer trace to one minor division (2/10) left of center between the “goal posts.” Figure B is improved from Figure D.

4. Final Analog:

Check the lateral alignment, as initially set using the “Buzz Track,” and correct as required. Confirm the L.E.D. positioning by setting the oscilloscope for “X-Y” display and running the Dolby Cat. No. 97 loop. A “cross” should appear on the screen. When both the horizontal and vertical lines are straight and of uniform length, the optimum position has been reached. Repeat the tests for focus, azimuth, equalization, and “Dolby” level set. A difference may be noted in that the high frequency range is extended, and very little high frequency boost will be required.

Simplex
Dual visible LED reader

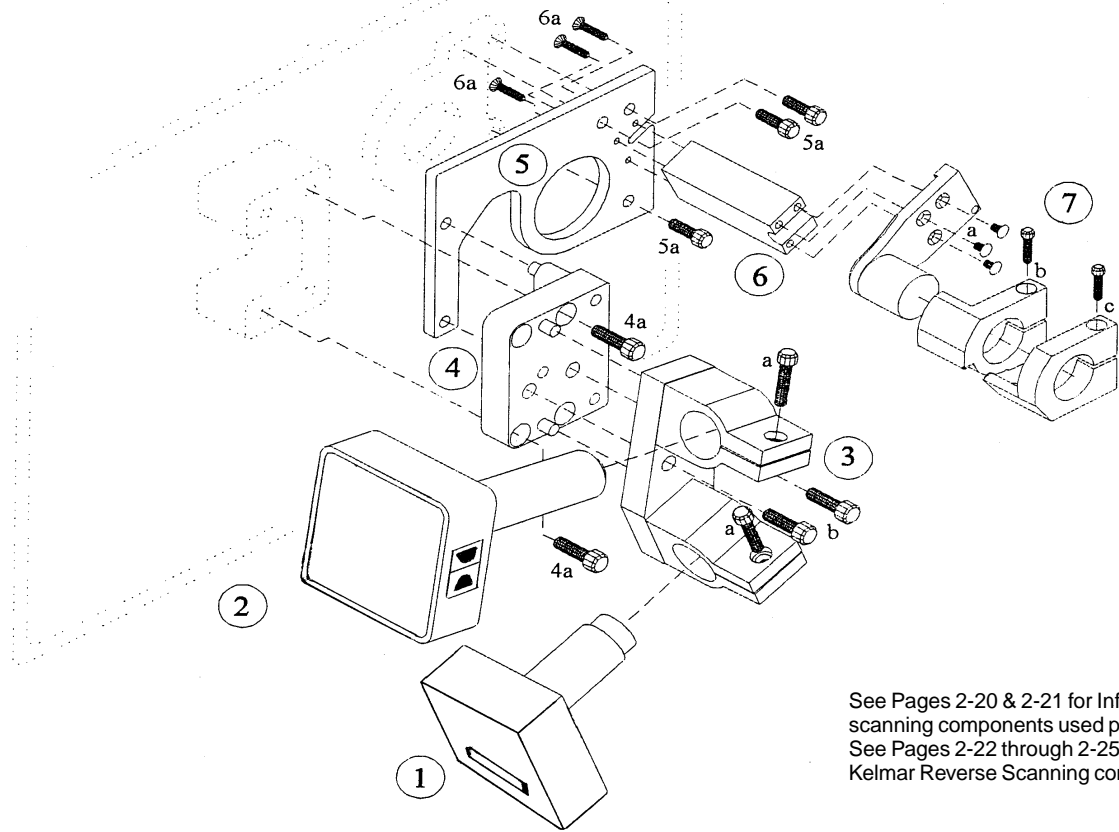

See Pages 2-20 & 2-21 for Infrared L.E.D. scanning components used prior to 1997. See Pages 2-22 through 2-25 for optional Kelmar Reverse Scanning components.

<u>Item</u>	<u>Part No.</u>	<u>Description</u>
1	51-30001	Signal Pick-Up Assembly, Analog
2	51-30002	Signal Pick-Up Assembly, Digital
3	51-98265	Mounting Bracket, Pick-Up Assemblies
3a	41-51566	Clamping Screw, 8-32 x 3/4"
3b	41-51607	Bracket Mounting Screw, 10-32 x 5/8"
4	51-98311	Adapter Block
4a	41-51556	Block Mounting Screw, 8-32 x 1/2"
5	51-98269	Locator Plate
5a	41-51556	Plate Mounting Screw, 8-32 x 1/2"
6	51-98308	Standoff Post, Spud Plate
6a	41-51364	Post Mounting Screw, 4-40 x 3/8"
7	51-98310	Spud Plate, L.E.D. Heads
-	51-30004	Analog L.E.D. Mounting Head (less L.E.D.)
-	51-30005	Digital L.E.D. Mounting Head (less L.E.D.)
-	51-30006	L.E.D. (for above)
7a	41-51364	Mounting Screw, 4-40 x 3/8"
7b	41-51566	Analog Head Clamp Screw
7c	41-51566	Digital Head Clamp Screw

PARTS NOT SHOWN:

51-98306	L.E.D. Power Supply, Analog only
51-98307	L.E.D. Power Supply, Analog & Digital
51-40034	Power Supply Module
51-98303	Power Supply Housing
51-98309	AC Cord, Power Supply
51-98272	Video Cable (30 ft.)
51-98278	Video Cable (60 ft.)

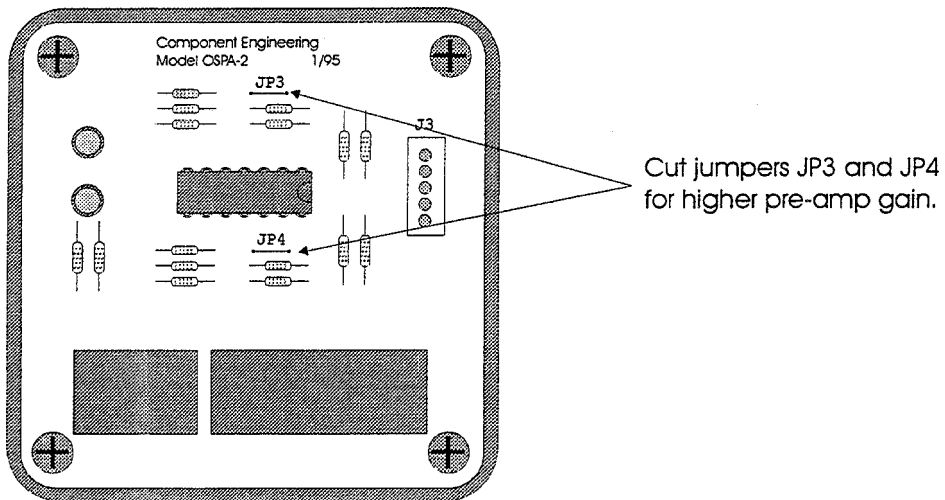

PART 2

5 STAR SOUNDHEAD

Top View

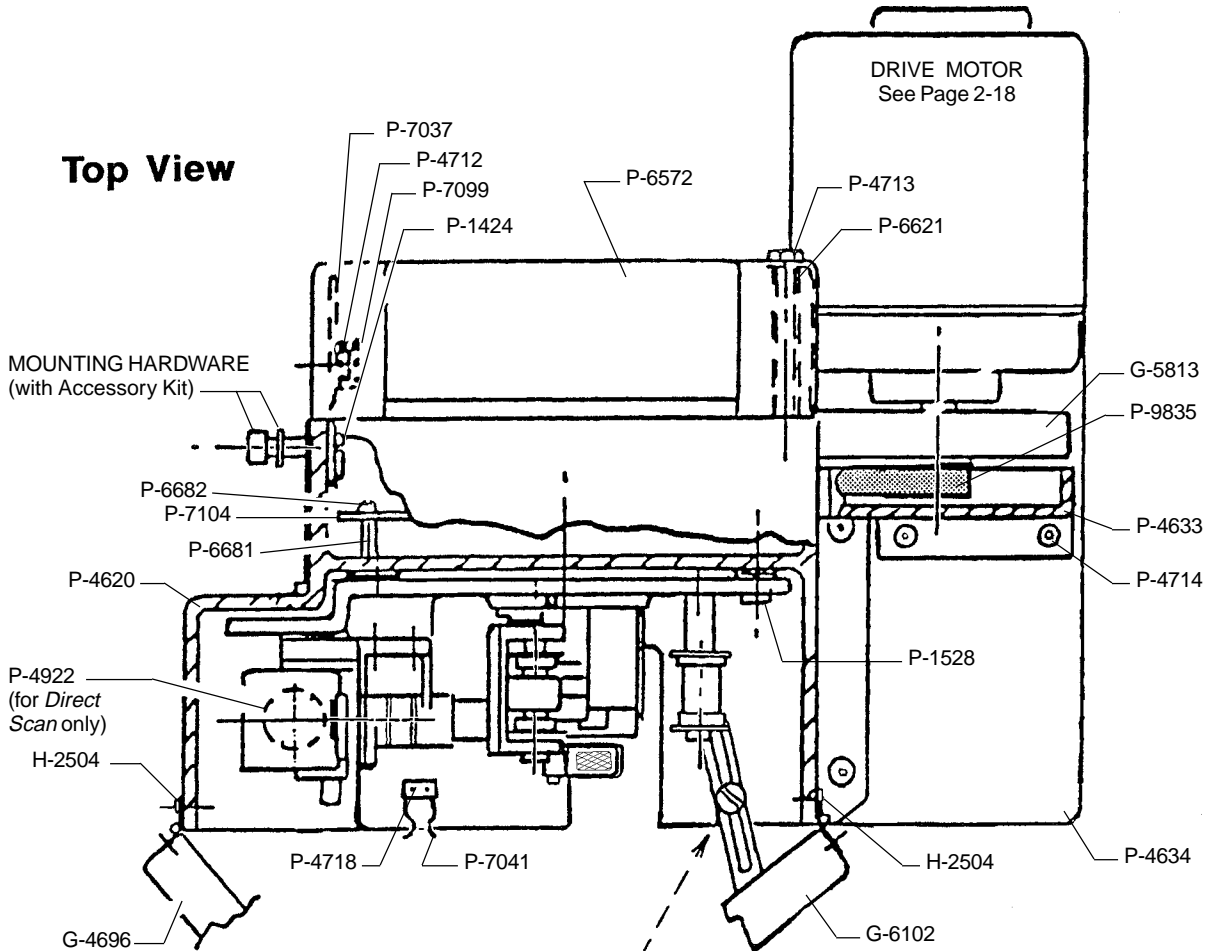

(DETAIL)

Partial Section

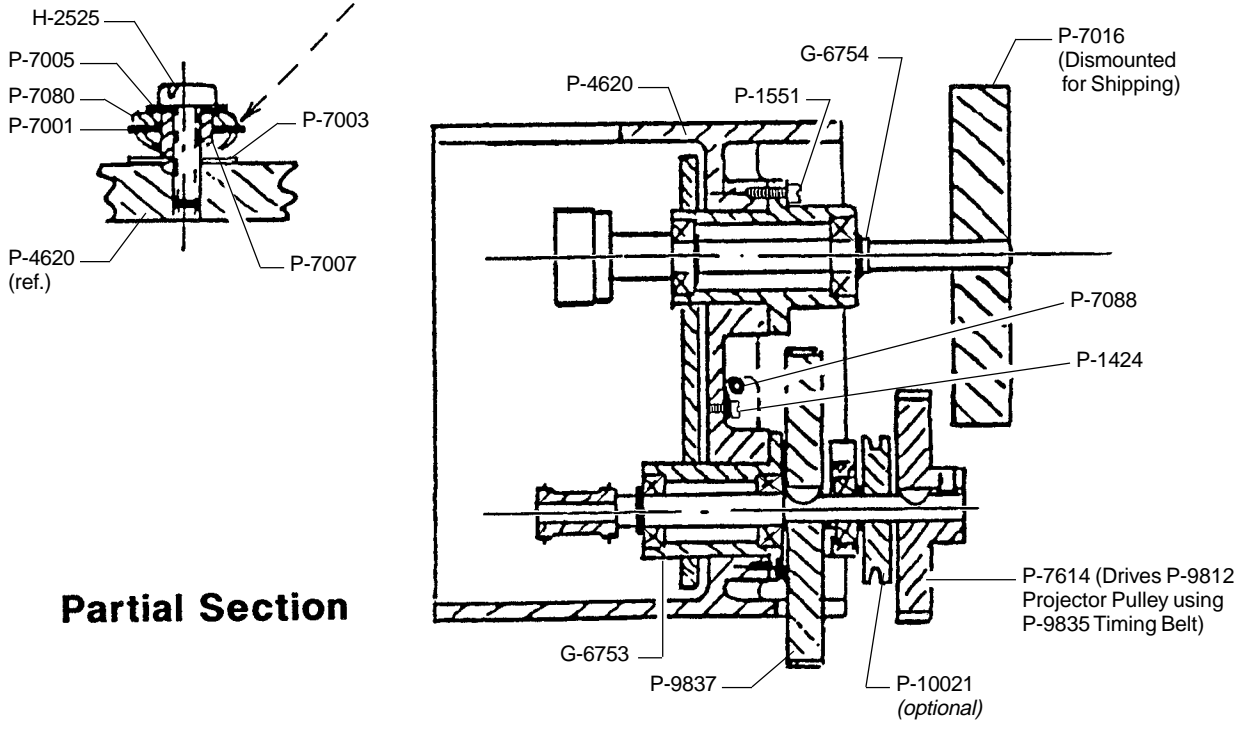

5 STAR SOUNDHEAD

Main Frame Overview

Parts List

G-4696	Door Assembly, Rear Compartment (see Page 2-10)
G-5813	Flywheel & Bushing Assembly (see Page 2-18)
G-6102	Door Assembly, Film Compartment (see Page 2-15)
G-6753	Sprocket Shaft Assembly (see Page 2-13)
G-6754	Impedance Drum Assembly (see Page 2-12)
G-7104	Terminal Board Assembly (Order 21-62010)
H-2504	Hinge Mounting Screw, 8-32 x 3/8"
H-2525	Screw, 6-32 x 1/2"
P-1424	Fastening Screw, 8-32 x 3/8"
P-1528	Clamping Screw, 10-32 x 5/8"
P-1551	Fastening Screw, 1/4-20 x 1/2"
P-7088	Clamp
P-4620	Soundhead Main Frame Casting
P-4633	Belt Guard
P-4634	Motor Mount Casting (see Page 2-18)
P-4712	Screw, 8-32 x 1/4"
P-4713	Fastening Screw, 10-32 x 3/8"
P-4714	Shoulder Bolt
P-4718	Screw, 4-40 x 1/4"
P-4922	Exciter Lamp (Direct Scan <i>only</i>); See Page 2-8
P-6572	Cover Casting, Off-Operator Side
P-6621	Stud
P-6681	Spacer, Terminal Block
P-6682	Screw, 6-32 x 1-1/4"
P-7001	Flat Washer
P-7003	Flat Washer
P-7005	Washer
P-7007	Washer
P-7036	Vent Plug (not shown)
P-7037	Connector Mounting Plate
P-7041	Door Catch
P-7080	Spring Washer
P-7088	Clamp
P-7099	Cable Clamp
P-7614	Timing Belt Pulley, Projector Drive*
P-9835	Timing Belt*
P-9837	Timing Belt Pulley, Soundhead Drive*
P-10021	V-Belt Pulley (Optional)

* See Page 2-19 for 230 V.AC, 50 Hz. Drive Components

COMPONENT LAYOUT & MOUNTING

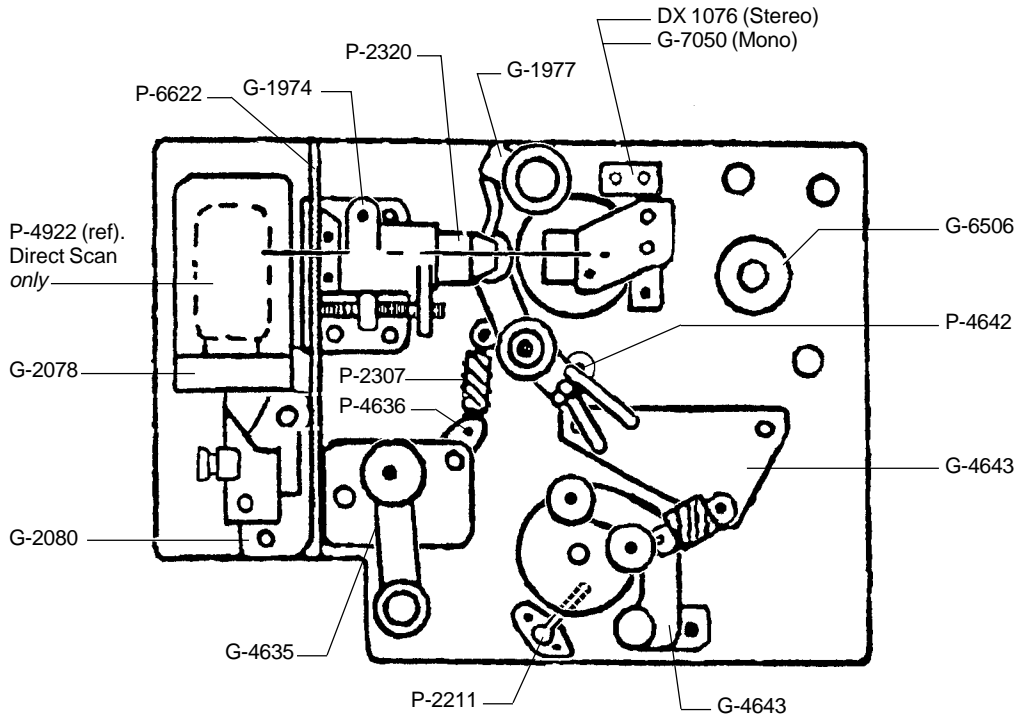

COMPONENT LAYOUT & MOUNTING

Parts List

DX1076	Stereo Solar Cell*	G-7050	Solar Cell Bracket (Mono)*
H-1503	Mounting Screw (3)	H-1503	Mounting Screw (3)
G-1974	Slit Lens Assembly*	P-2211	Stripper, Film Sprocket
H-1503	Mounting Screw (4)	H-1501	Mounting Screw (2)
G-1977	Lateral Guide Roller	P-2307	Expansion Spring
G-2078	Exciter Lamp Bracket*	P-2320	Slit Lens*
G-2080	Exciter Lamp Base*	P-4636	Extension Stud, Standoff
H-1503	Mounting Screw (3)	P-4642	Stop Pin, Guide Roller
G-4635	Damper Roller Assembly	P-4922	Bulb, Exciter Lamp*
H-1503	Mounting Screw (2)	P-6622	Light Shield
G-4643	Pad Roller Assembly	P-1538	Mounting Screw (2)
G-6506	Idler Roller Assembly		

* Direct Scan Components shown; see Page 1-14 for Reverse Scan Components. Exciter Lamp & Associated Components *not required* with Reverse Scan.

G-1974 SOUND OPTIC ASSEMBLY

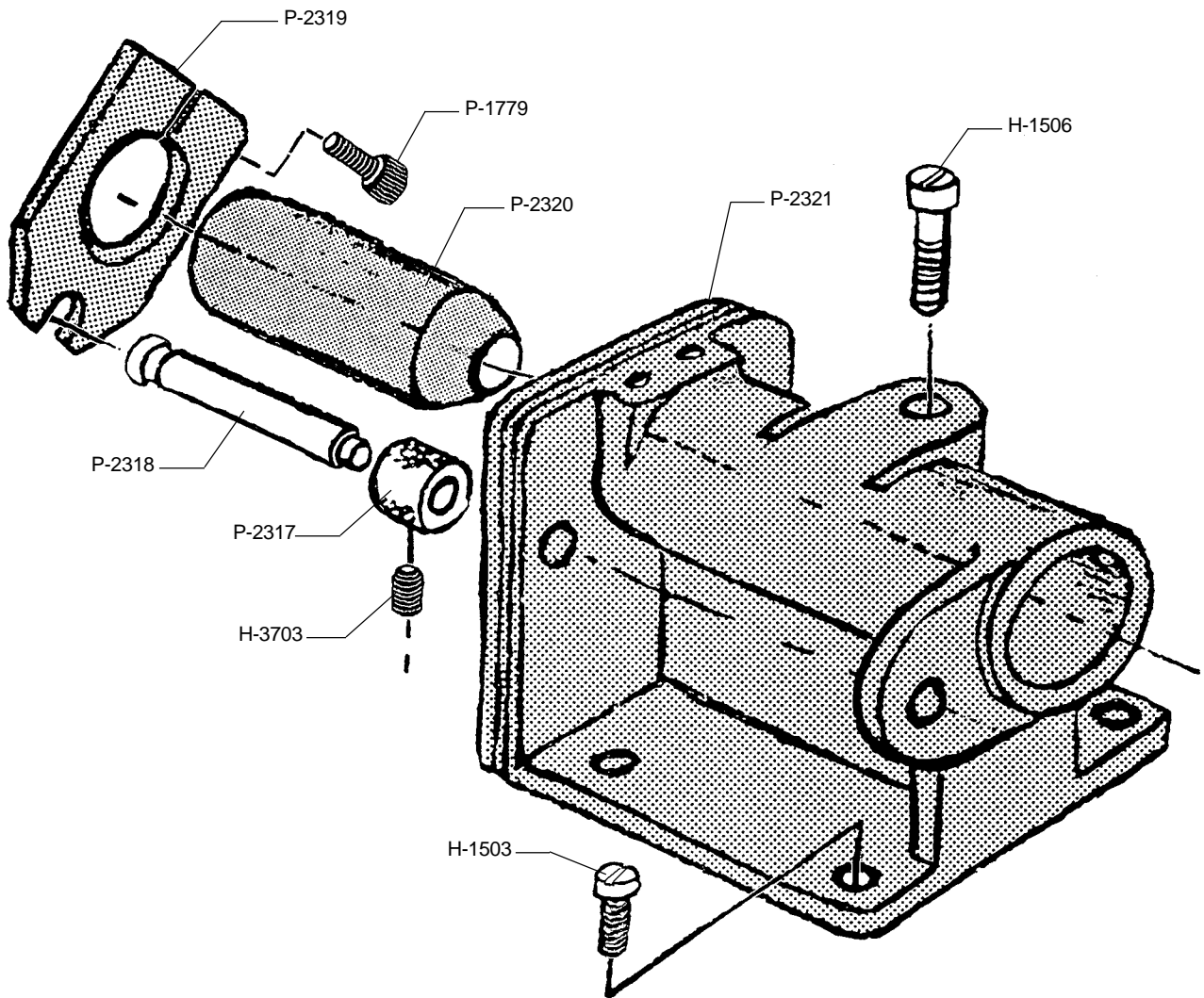

G-1974 SOUND OPTIC ASSEMBLY

(Used on *Direct Scan & Analog-only Reverse Scan* models)

P-2317	Adjustment Nut, Focus
P-2318	Adjustment Screw
P-2319	Lens Clamp
P-2320	Slit Lens, .8 mil (21-98116)
P-2320A	Slit Lens, .47 mil (21-98117)
P-2321	Mounting Bracket, Cast
P-1779	Clamping Screw, 6-32 x 7/8" Socket Head
H-1503	Mounting Screw, 8-32 x 1/2" Fillister Head (4 req'd.)
H-1506	Clamping Screw, 8-32 x 3/8" Fillister Head
H-3703	Set Screw, 6-40 x 3/16"

G-1977 LATERAL GUIDE ROLLER

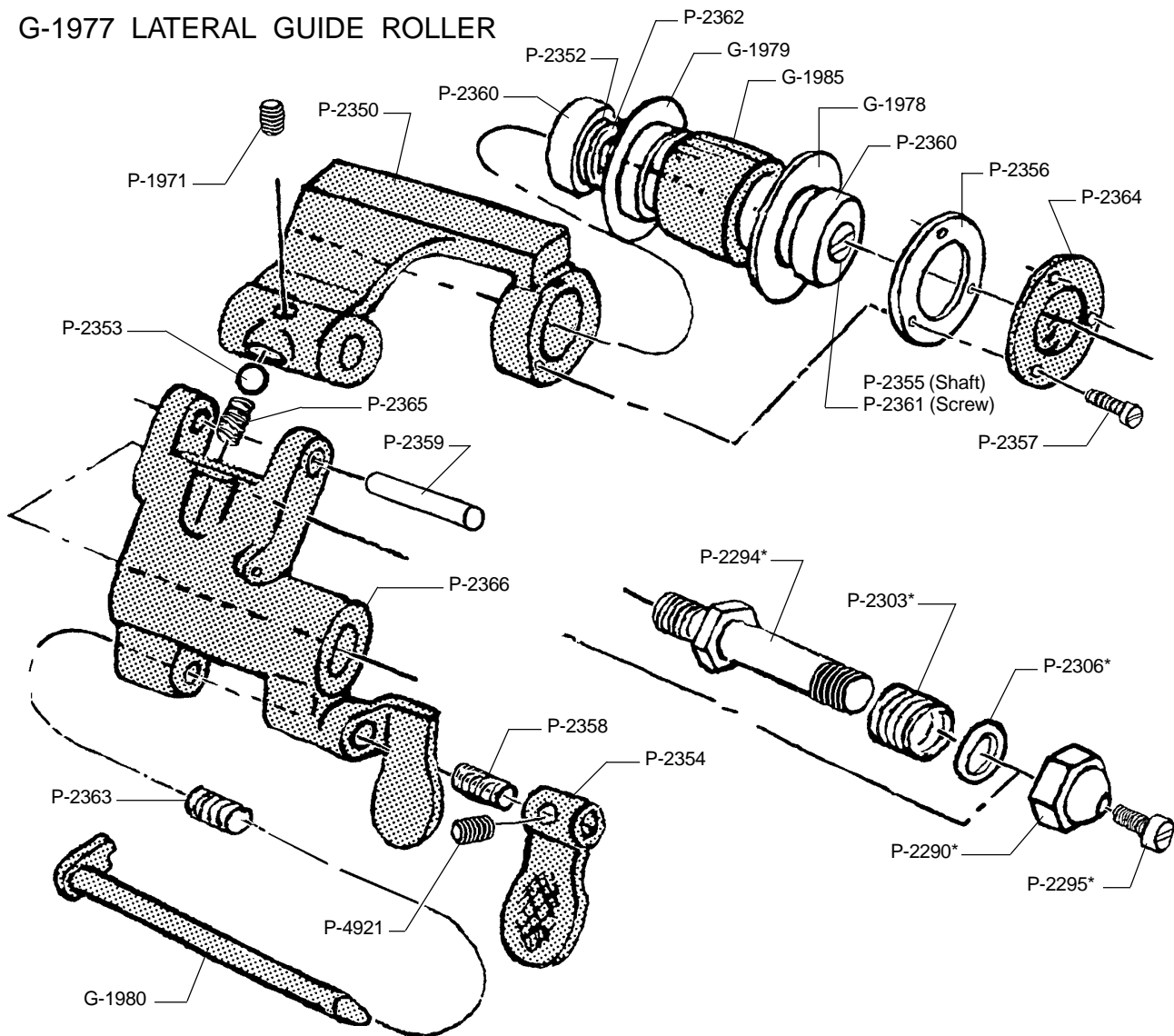

G-1977 LATERAL GUIDE ROLLER ASSEMBLY

G-1978	Roller Assembly, Outboard	P-2355	Roller Shaft
G-1979	Roller Assembly, Inboard	P-2356	Spacer Plate
G-1980	Shaft & Arm Assembly	P-2357	Screw, 2-56 x 5/16" Flat Head
G-1985	Friction Roller	P-2358	Compression Spring
P-1971	Set Screw (2), 6-32 x 1/8"	P-2359	Pivot Pin
P-2290*	Stop Nut	P-2360	Ball Bearing (2)
P-2294*	Mounting Stud	P-2361	Screw, 5-40 x .3282" (2)
P-2295*	Lock Screw, Stop Nut	P-2362	Compression Spring
P-2303*	Compression Spring	P-2363	Compression Spring
P-2306*	Spacer Washer	P-2364	Cover Plate
P-2350	Upper Bracket, Cast	P-2365	Compression Spring
P-2352	Spacer Washer	P-2366	Lower Bracket, Cast
P-2353	Steel Ball	P-4621	Set Screw, 6-32 x 1/4" Square Head
P-2354	Operating Lever		

* Not included with G-1977; order separately

G-4635 DAMPER ASSEMBLY

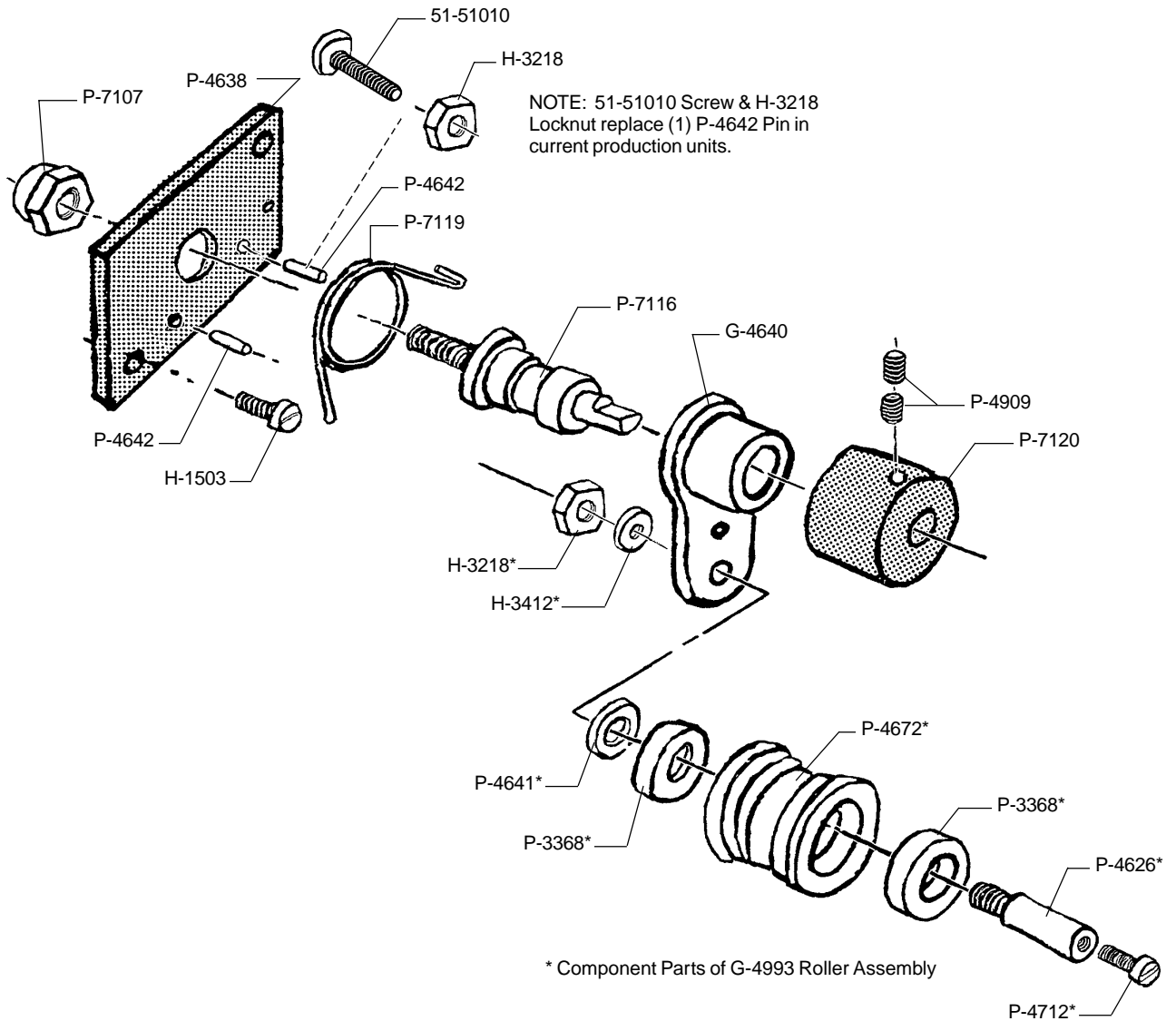

G-4635 DAMPER ASSEMBLY

G-4640	Arm Assembly	H-1503	Mounting Screw (2), 8-32 x 1/2"
G-4993	Roller Assembly <i>consists of:</i>	P-4638	Plate
H-3218	Hex Nut, 10-32	P-4642	Pin (2), 1/8 x 1/2"
H-3412	Washer, #10	P-4909	Set Screw, 6-32 x 3/16"
P-3368	Ball Bearing (2)	P-7107	Stop Nut
P-4626	Roller Stud	P-7116	Shaft
P-4641	Spacer	P-7119	Torsion Spring
P-4672	Guide Roller, 35mm	P-7120	Cap
P-4712	Screw, 8-32 x 1/4"	P-4807	Damping Fluid, 1.5cc (not shown)

G-4643 PAD ROLLER ASSEMBLY

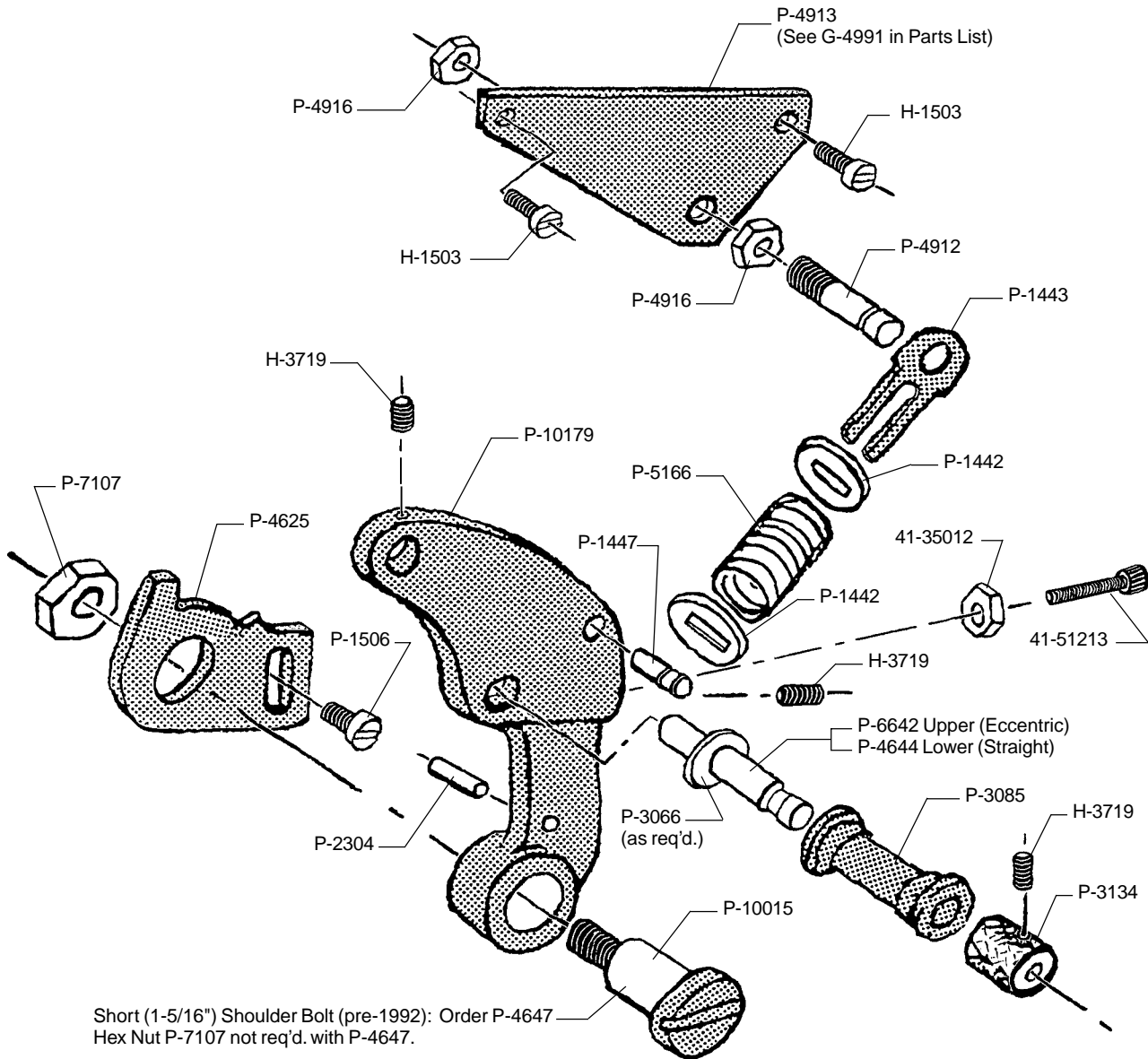

Short (1-5/16") Shoulder Bolt (pre-1992): Order P-4647
Hex Nut P-7107 not req'd. with P-4647.

P-10179 + P-1447: Order 52-60242

G-4643 PAD ROLLER ASSEMBLY

G-4991	Plate & Stud Assembly (P-4913, P-4912 & P-4916)	P-4644	Pad Roller Shaft, Straight
H-1503*	Screw, 8-32 x 1/2"	P-4912	Stud, Spring Guide
H-1506*	Screw, 8-32 x 3/8"	P-4913	Plate
H-3719	Set Screw (4), 8-32 x 1/4"	P-4916	Hex Nut, 10-32 (2)
P-1442	Spring Retainer (2)	P-4916	Hex Nut, 10-32 (2)
P-1443	Spring Guide	P-5166	Compression Spring
P-1447	Pin, Grooved	P-6642	Pad Roller Shaft, Eccentric
P-2304	Stop Pin (early models)	P-7107*	Stop Nut
P-3066	Spacer Washer (as req'd.)	P-10015*	Shoulder Bolt, 1-3/4"
P-3085	Pad Roller (2)	P-10179	Casting, Pad Roller Arm
P-3134	Knurled Knob (2)	41-35012	Lock Nut, 10-32
P-4625*	Plate	41-51213	Stop Screw, 10-32 x 1"
			* Not included with G-4643; order separately

G-2078 EXCITER LAMP BRACKET ASSEMBLY

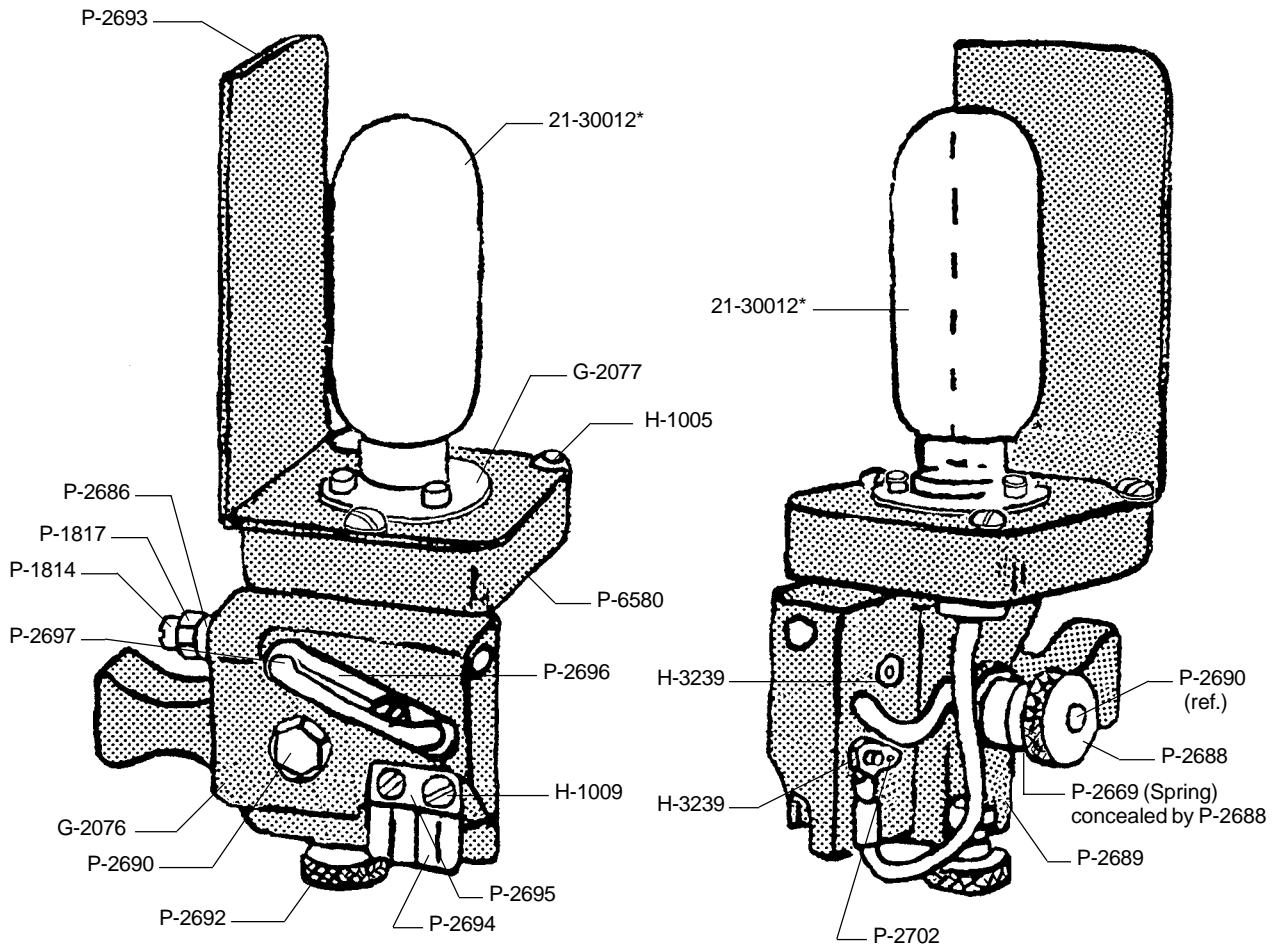

G-2078 EXCITER LAMP BRACKET ASSEMBLY

(Required for *Direct Scan* models only)

G-2076	Lower Bracket	P-2693	Light Shield
G-2077	Lamp Socket	P-2694	Contact Spring
P-1814	Screw, 6-32 x 5/8"	P-2695	Retainer
P-1817	Lock Nut, 6-32	P-2696	Contact Spring
P-2669	Spring	P-2697	Contact
P-2686	Bushing	P-2702	Plate
P-2688	Knurled Nut	P-6580	Upper Bracket
P-2689	Locking Bar	H-1005	Screw, 6-32 x 1/4" (3)
P-2690	Locking Stud	H-1009	Screw, 6-32 x 5/8" (4)
P-2692	Adjusting Screw	H-3239	Hex Nut, 6-32 (2)

* Exciter Lamp (9 Volt, 4 Amp.) not included with G-2078; *order separately.*

G-2080 EXCITER LAMP BASE

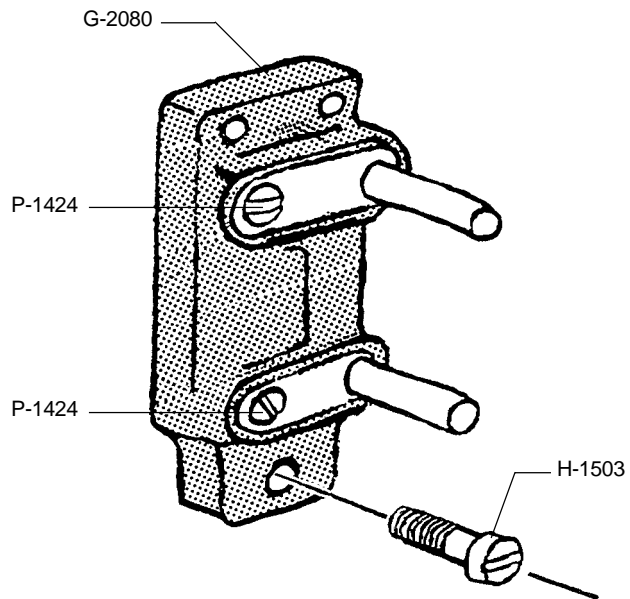

G-2080 EXCITER LAMP BASE (Required for *Direct Scan* models only)

G-2080	Molded Base & Contacts Assembly
P-1424	Contact Screw (2), 8-32 x 3/8"
H-1503	Mounting Screw (3), 8-32 x 1/2"

G-4696 REAR COMPARTMENT ACCESS DOOR

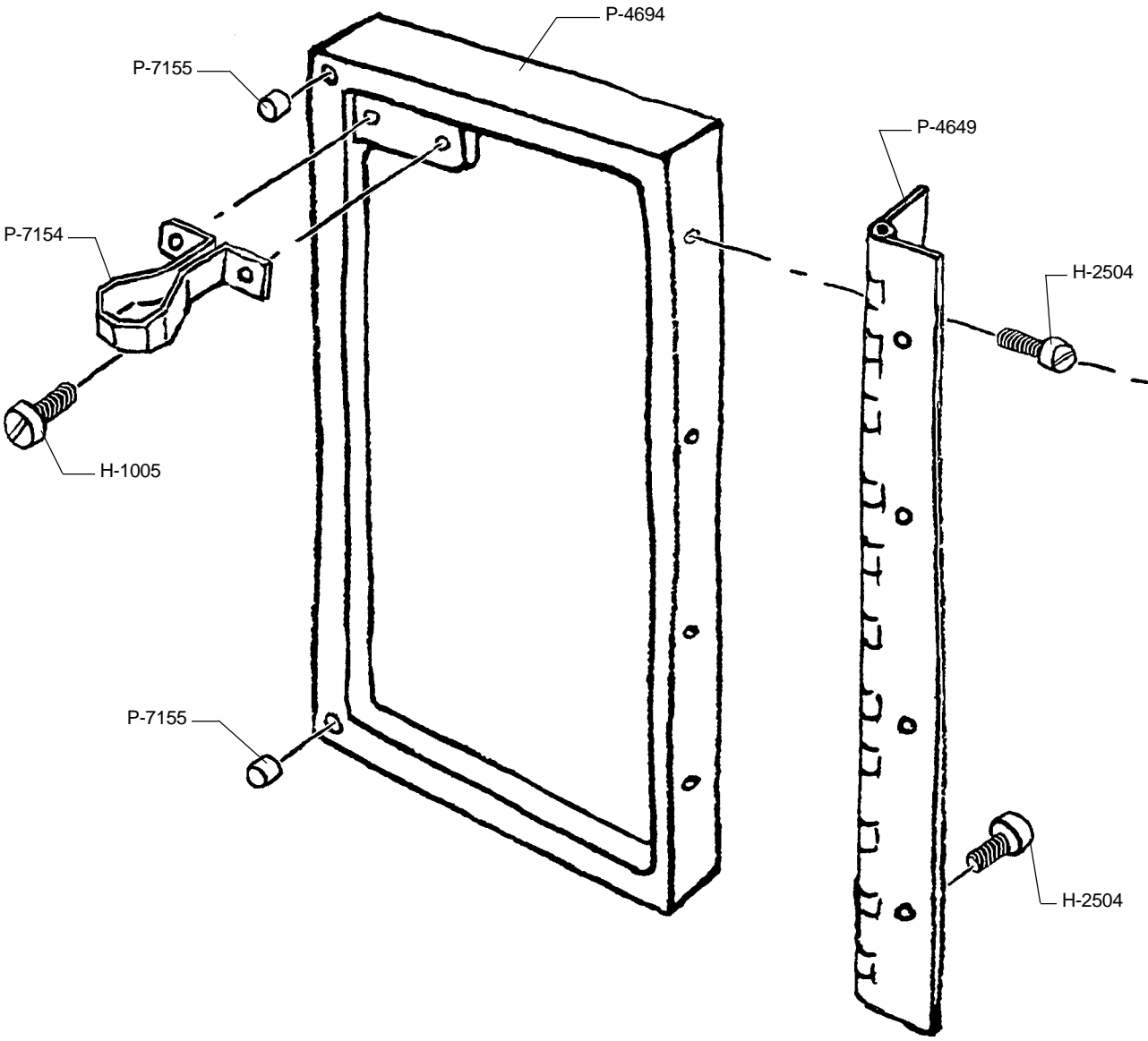

G-4696 ACCESS DOOR, REAR

- P-4649 Hinge
- P-4694 Door Casting
- P-7154 Strike, Door Latch
- P-7155 Cushion, Door Stop (2)
- H-1005 Screw (2), 6-32 x 1/4"
- H-2504 Screw (8), 8-32 x 3/8"

G-5813 FLYWHEEL & PULLEY ASSEMBLY

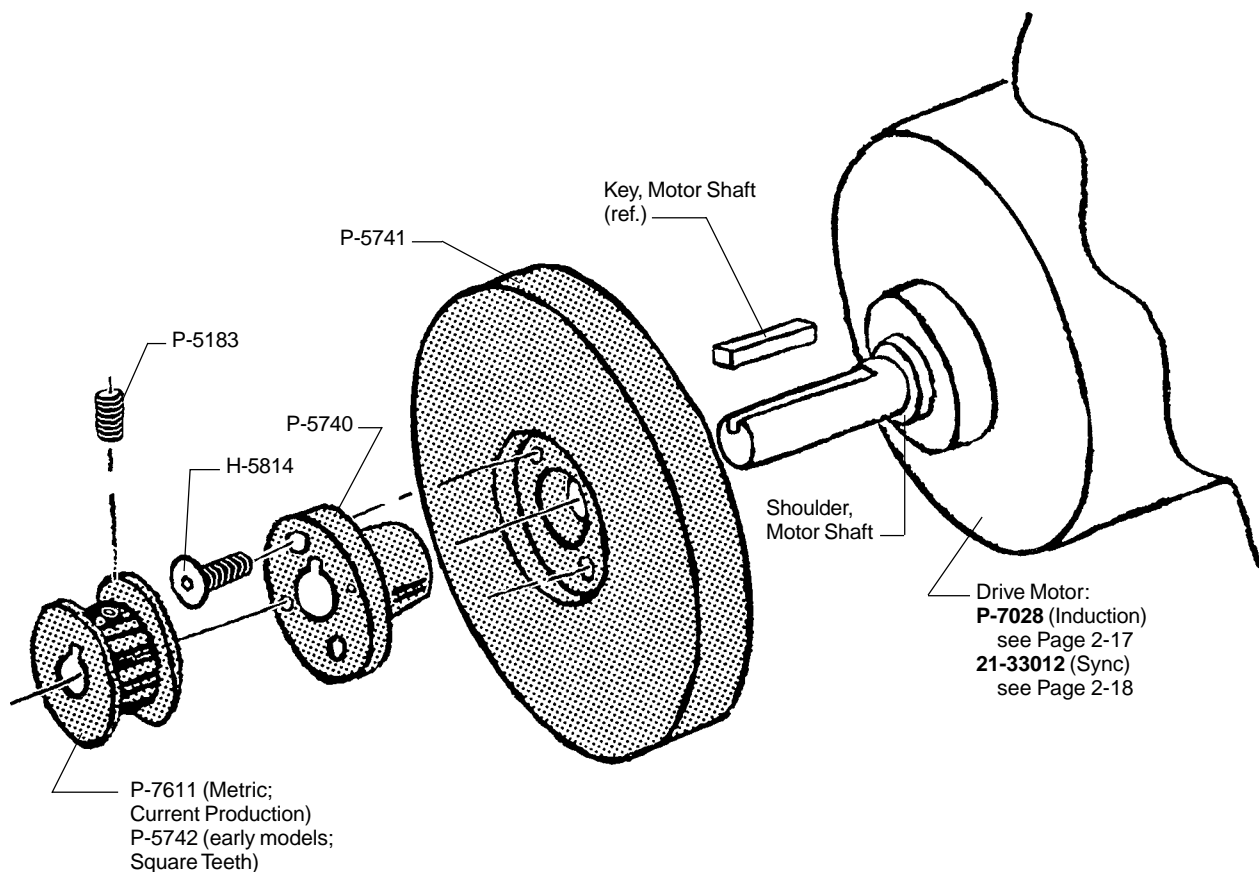

G-5813 FLYWHEEL & PULLEY ASSEMBLY

P-5183	Set Screw (2), 10-32 x 1/8"
P-5740	Split Hub, Taper Lock
P-5741	Flywheel
P-5742	Pulley (Square Tooth; Old Style)
P-7611	Pulley (Metric; Current Production)
H-5814	Screw (2), 1/4-20 x 3/4" Flat Head

ASSEMBLY PROCEDURE:

1. Assemble Flywheel & Hub as shown using (2) H-5814 Screws. Do not tighten screws. Slide assembly over Motor Shaft & Key until P-5740 touches the shoulder of the Motor Shaft. Tighten the H-5814 screws, alternating to prevent cocking the Flywheel.
2. Slide Pulley over Motor Shaft & Key and position so that it lines up with the large pulley P-7614 on Sprocket Shaft P-6571 (see Page 2-13). Tighten (2) Set Screws P-5183.
3. To dismount Flywheel from Motor Shaft, remove Pulley and unscrew the (2) H-5814 screws. Insert the H-5814 screws into the (2) tapped screws in the P-5740 Hub and tighten until the Flywheel is released.

G-6754 IMPEDANCE DRUM ASSEMBLY

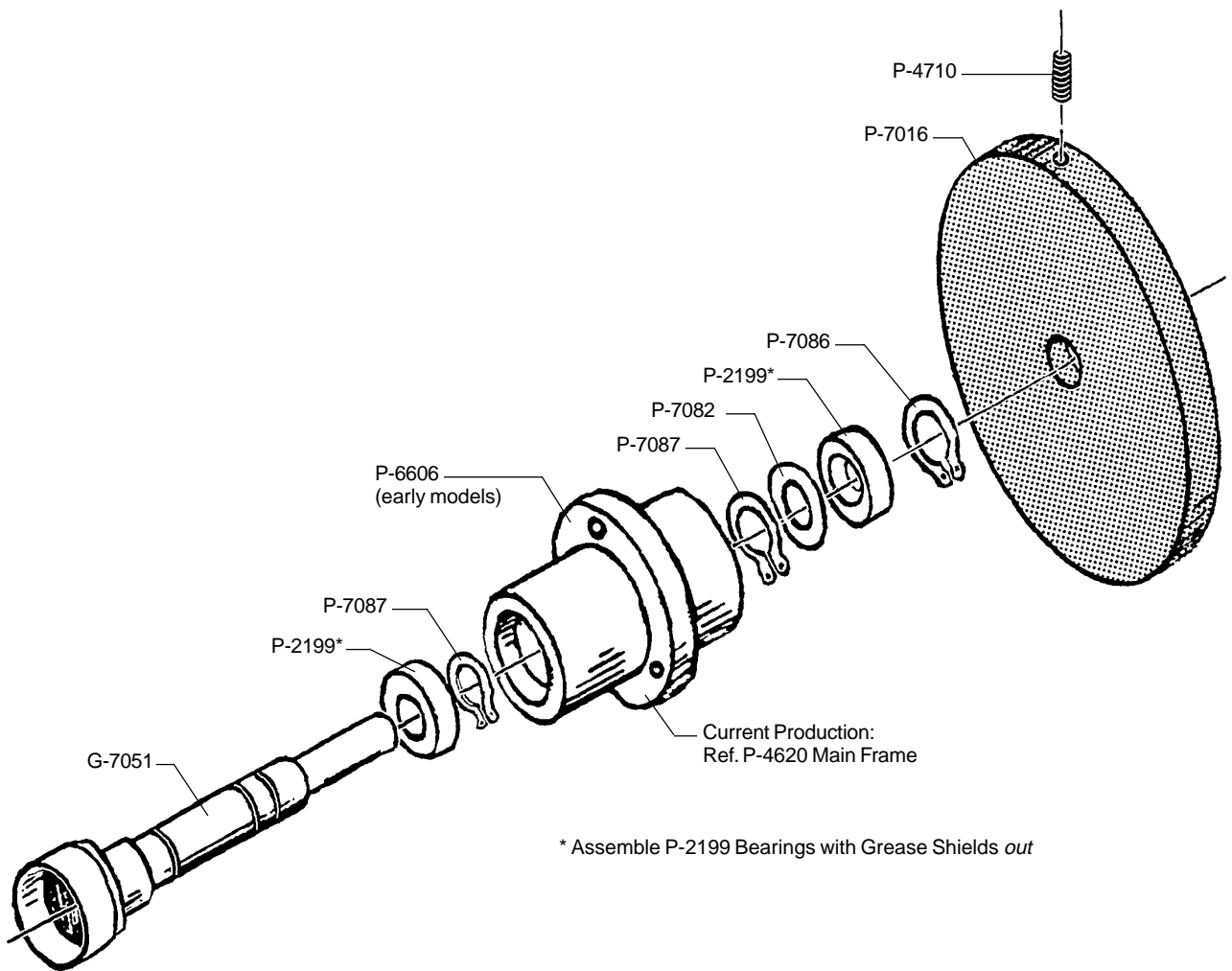

G-6754 IMPEDANCE DRUM ASSEMBLY

(Not Sold as an Assembly)

G-7051	Impedance Drum
P-2199	Ball Bearing (2)
P-4710	Set Screw, Self-Locking
P-6606	Bearing Block (early models)
P-7016	Flywheel
P-7082	Spring Washer
P-7086	Retaining Ring
P-7087	Retaining Ring (2)

G-6753 SPROCKET SHAFT ASSEMBLY

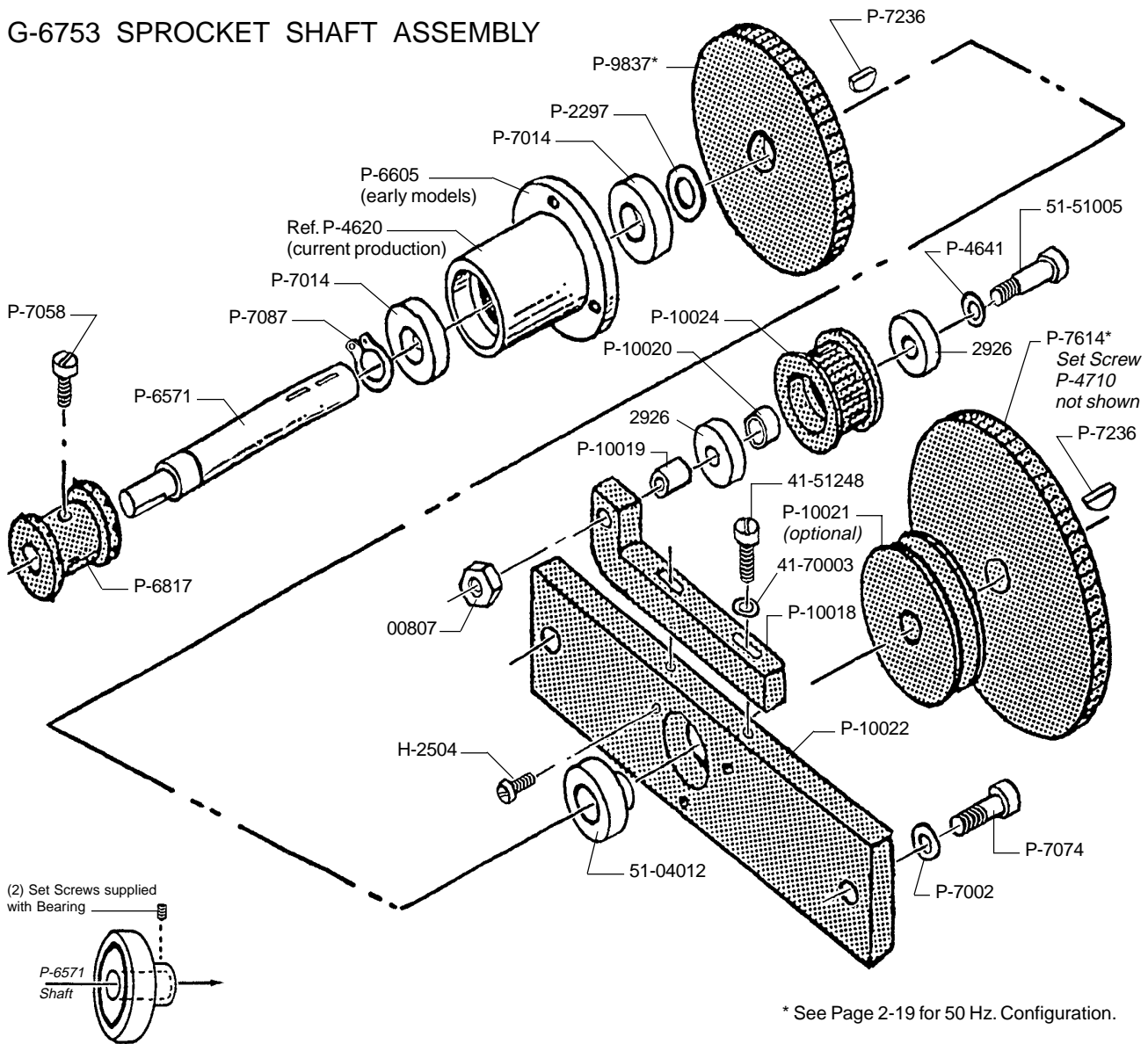

* See Page 2-19 for 50 Hz. Configuration.

G-6753 SPROCKET SHAFT ASSEMBLY

(Not Sold as an Assembly)

H-2504	Screw, 8-32 x 3/8"	P-9837	Soundhead Driven Pulley (60 Hz.)
P-2297	Spacer Washer (2)	P-10018	Belt Tension Arm
P-4710	Set Screw, Self Locking	P-10020	Spacer Bushing
P-6571	Sprocket Shaft	P-10020	Bearing Spacer
P-6605	Bearing Block (early models)	P-10022	Bearing Support Plate
P-6817	Film Sprocket, 35mm VKF®	P-10024*	Idler Pulley, Belt Tension
P-7002	Washer, 1/4"	00807	Hex Nut, 5/16-18
P-7014	Ball Bearing (2)	2926	Ball Bearing (2); Order 21-04023
P-7058	Screw, 8-32 x 5/16"	51-04012	Ball Bearing, Wide Inner Race
P-7073	Screw, 10-32 x 3/4"	51-51005	Shoulder Bolt, 1-1/2" x 3/8" Dia.
P-7074	Screw, 1/4-20 x 1"	52-60364*	Idler Pulley Assembly
P-7087	Retaining Ring	(P-10024 with P-10020 & two 2926)	
P-7239	Woodruff Key (2)	52-60039	Upgrade Kit (allows use of 51-04012
P-7614	Projector Drive Pulley (60 Hz.)	Bearing in units below s/n 9600 S)	

G-6506 IDLER ROLLER ASSEMBLY

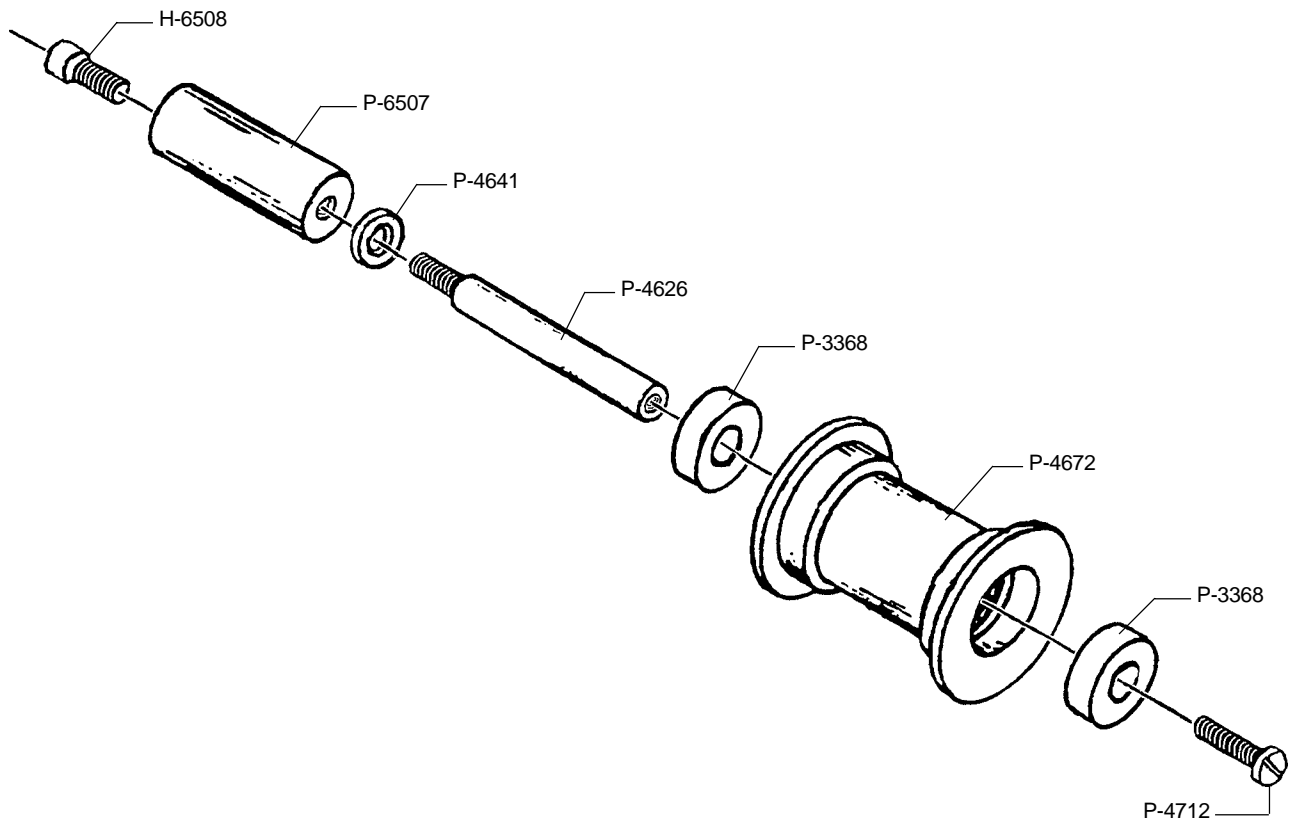

G-6506 IDLER ROLLER ASSEMBLY

P-3368	Ball Bearing (2)
P-4626	Roller Shaft
P-4641	Spacer
P-4672	Film Roller, 35mm
P-4712	Screw, 8-32 x 1/4"
P-6507	Spacer Stud
H-6508	Screw, 10-32 x 1/2"

G-6102 FILM COMPARTMENT DOOR ASSEMBLY

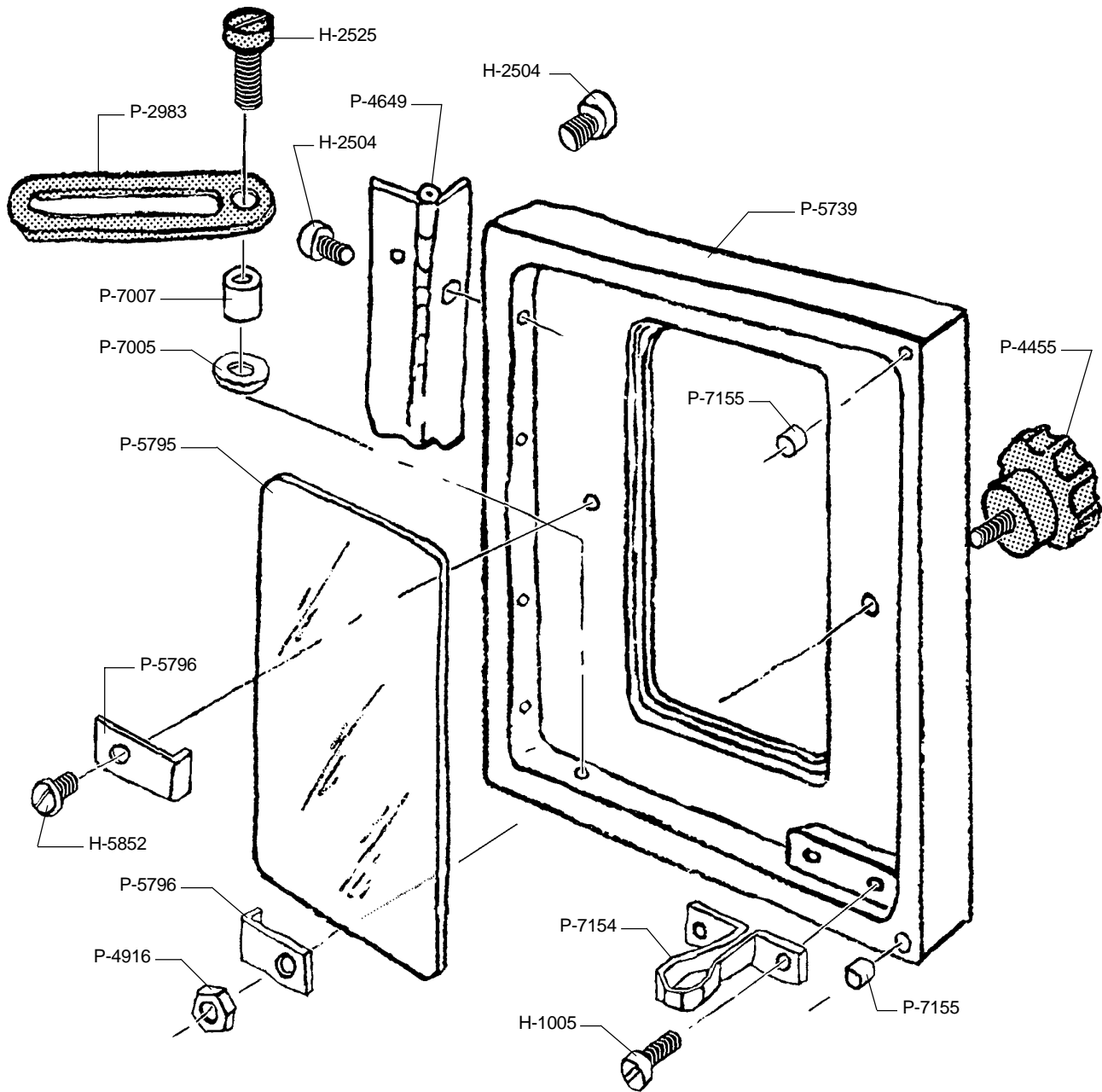

G-6102 FILM COMPARTMENT DOOR ASSEMBLY

P-2983	Door Stay	P-7007	Spacer Bushing
P-4455	Knob	P-7154	Strike, Door Latch
P-4649	Hinge	P-7155	Cushion (2)
P-4916	Hex Nut, 10-32	H-1005	Screw (2), 6-32 x 1/4"
P-5739	Door Casting	H-2504	Screw (4), 8-32 x 3/8"
P-5795	Window, Plexiglass	H-2525	Screw, 6-32 x 1/2"
P-5796	Window Clip (2)	H-5852	Screw, 2-56 x 1/2"
P-7005	Washer (2), #6		

SOLAR CELL ASSEMBLIES
(Direct Scan only)

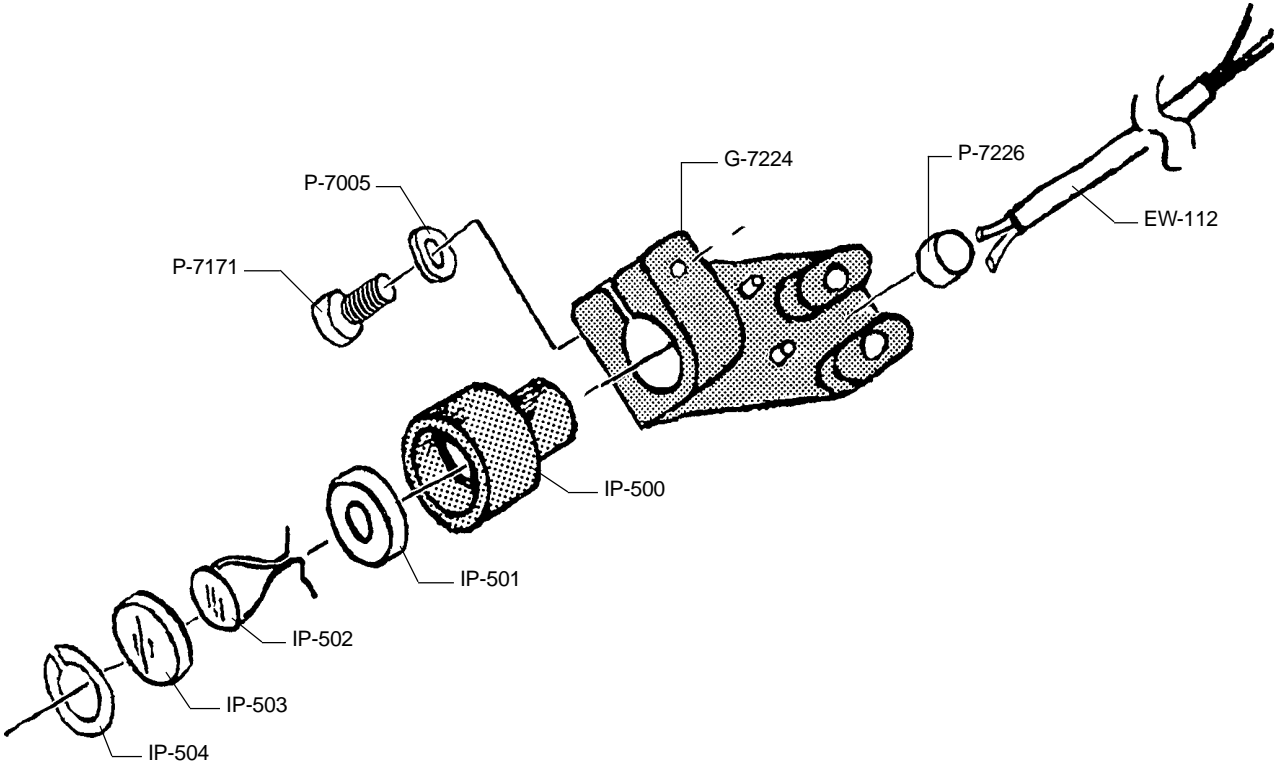

G-7050 SOLAR CELL & BRACKET ASSEMBLY
(Direct Scan, Monophonic)

G-7224	Bracket & Terminal Assembly	IP-500	Holder, Solar Cell
P-7005	Washer, #6	IP-501	Pad
P-7171	Clamping Screw	IP-502	Solar Cell
P-7226	Wire Retainer	IP-503	Window
EW-112	Cable	IP-504	Retaining Ring

DX 1076 SPLIT SOLAR CELL & BRACKET ASSEMBLY (not shown)
(Direct Scan, Stereo Variable Area)

Order 54-68025

G-7209 MOTOR MOUNT ASSEMBLY
 115 V.AC Induction Motor (pre-1990)

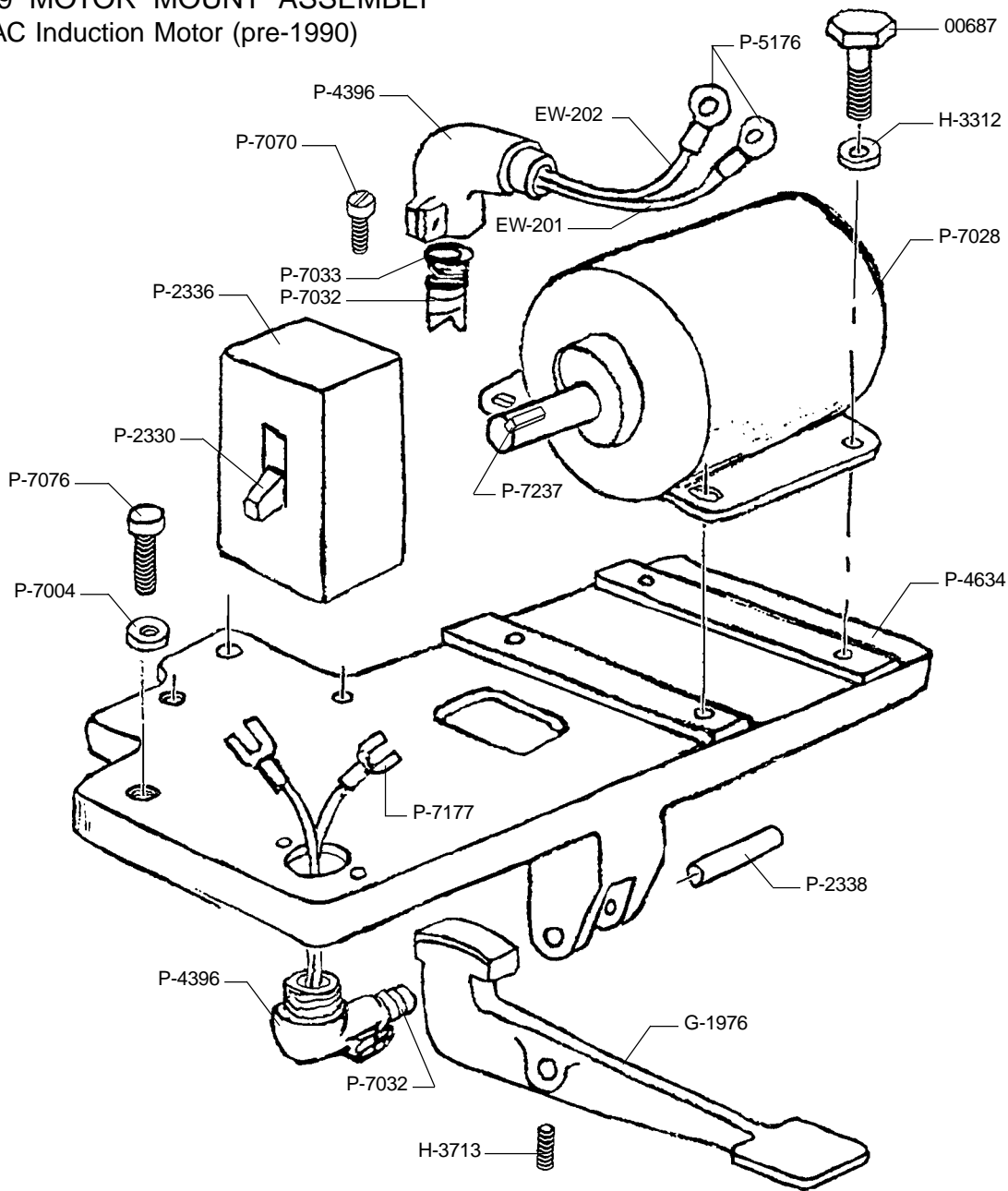

G-7209 MOTOR MOUNT ASSEMBLY
 (115 V.AC Induction Motor)

00687	Screw (4), 1/4-20 x 1/2"	P-5176	Ring Terminal (2)
EW-201	Wire, Motor Lead	P-7004	Washer (4), 5/16"
EW-202	Wire, Motor Lead	P-7028	Motor, 115 V.AC Induction
G-1976	Arm, Hand Brake	P-7032	Cable, Switch Box
H-3312	Washer (4), 1/4"	P-7032	Conduit Box
H-3713	Set Screw, 8-32 x 3/8"	P-7033	Insulator
P-2330	Switch, Motor On-Off	P-7070	Screw (2), 8-32 x 3/8"
P-2336	Switch Box	P-7076	Screw (4), 5/16-18 x 1"
P-2338	Pivot Pin	P-7177	Spade Lug (2)
P-4396	Connector, 90° (2)	P-7237	Key, Motor Shaft
P-4634	Motor Mount Casting		

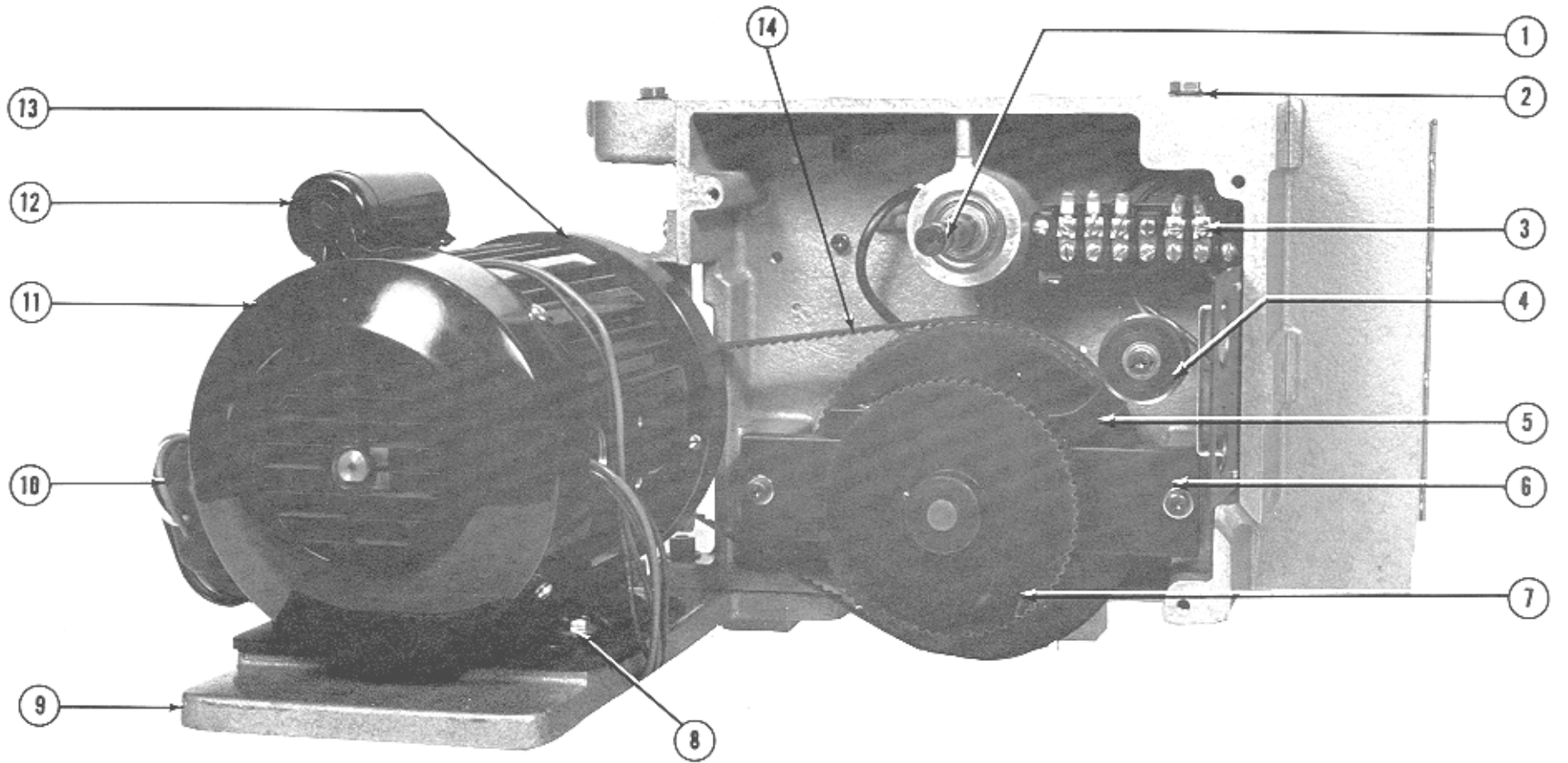

SYNCHRONOUS DRIVE MOTOR ASSEMBLY

SYNCHRONOUS DRIVE MOTOR ASSEMBLY

Parts List

<u>Item</u>	<u>Part No.</u>	<u>Description</u>
1	G-6754	Impedance Drum Assembly (see p. 2-12)
2	41-51139	Bolt, 5/16-18 x 1" Hex Head
-	P-2396	Mounting Bar
-	H-2745	Bolt, 3/8-16 x 3/4" Socket Head
3	21-62010	Barrier Strip, (6) Terminal
4	52-60364	Idler Pulley Assembly (s/n 9600S and up; see p. 2-13)
-	P-10024	Pulley, Metric (less Bearings & Spacer)
4	G-7052	Idler Pulley Assembly (square teeth)
5	P-9837	Timing Belt Pulley, Round Tooth Metric (60 Hz.)
5	P-7371	Timing Belt Pulley, Square Tooth (60 Hz.)**
5	52-20550	Timing Belt Pulley, Round Tooth Metric (50 Hz. *)
6	P-10022	Idler Support Plate (s/n 9600S and up; see p. 2-13)
6	P-7022	Idler Support Plate (early models)
7	P-7614	Timing Belt Pulley, Round Tooth Metric
7	P-7019	Timing Belt Pulley, Square Tooth**
8	00687000	Screw, 1/4-20 x 1/2" Hex Head
-	00852000	Flatwasher, 1/4"
-	P-7254	Motor Mounting Plate
-	41-51225	Screw, 1/4-20 x 5/8" Flat Socket Head
-	22-40909	Shock Mount Washer, Large
-	22-40910	Shock Mount Washer, Small
-	51-07011	Rubber Bushing
9	P-4634	Motor Support Casting
10	21-08149	Motor RUN Capacitor
11	21-33012	Synchronous Motor, 115 V.AC, 60 Hz.
11	21-33045	Synchronous Motor, 230 V.AC, 50 Hz.*
12	21-08150	Motor START Capacitor
13	G-5813	Flywheel & Bushing Assembly
-	H-5814	Screw, Taper Lock Bushing
-	P-7611	Drive Pulley, Round Tooth Metric
-	P-5742	Drive Pulley, Square Tooth**
14	P-9835	Timing Belt, 15mm Round Tooth (60 Hz.)
14	P-7021	Timing Belt, Square Tooth (60 Hz.)**
14	51-05015	Timing Belt, Round Tooth Metric (50 Hz. *)

* 52-60279 Sync Motor Drive Kit, 230 V.AC, 50 Hz. (Export)

** Pre-1990 Models use Square-Tooth Timing Belt Pulleys & Belts.
See PARTS LIST ADDENDUM, Inside Back Cover, Simplex 35 Parts Catalogue.

REVERSE SCAN COMPONENTS
(Infrared L.E.D.)

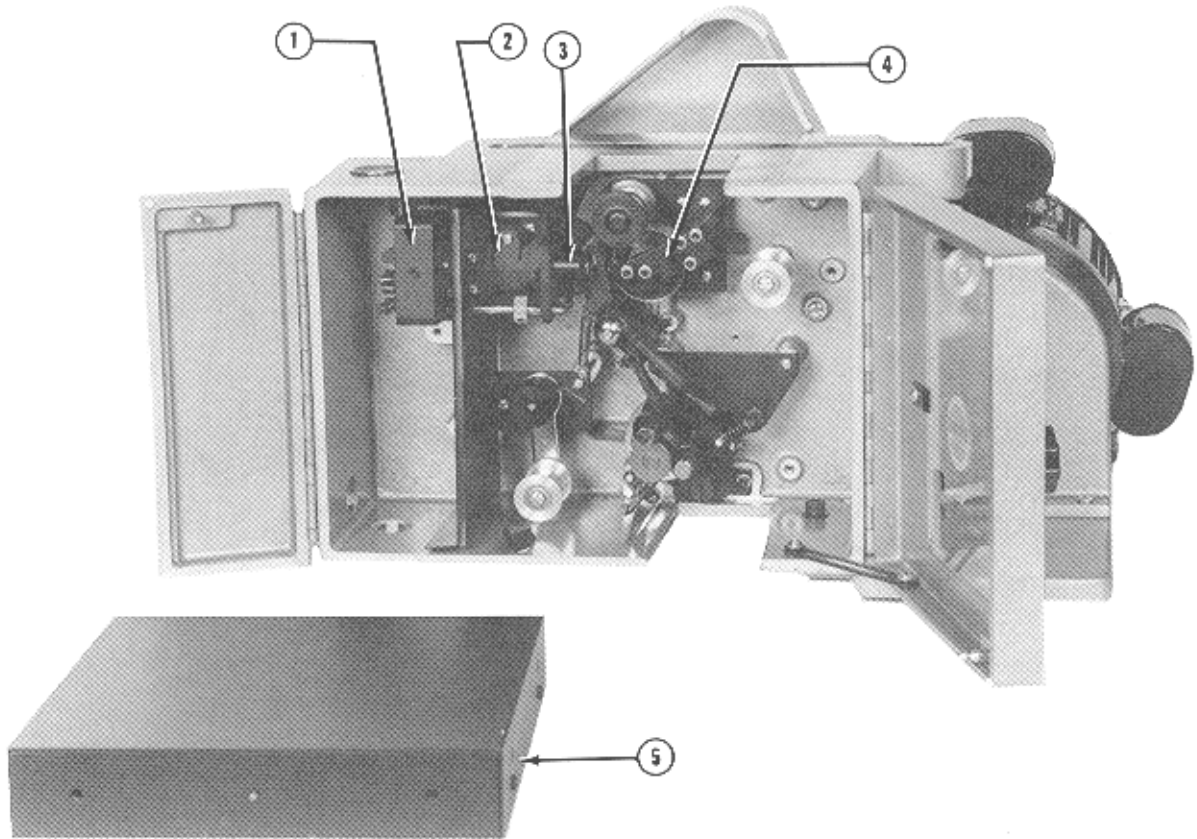

PARTS LIST

<u>Item</u>	<u>Part No.</u>	<u>Description</u>
1	51-98262	Signal Pick-Up Assembly, Analog
2	P-2321	Mounting Bracket (see Page 2-4)
-	H-1503	Mounting Screw (4 req'd.)
3	51-98262	Signal Pick-Up Assembly, Analog
4	51-98263	L.E.D. Illuminator & Bracket Assembly
-	H-1503	Mounting Screw (3 req'd.)
5	51-98264	L.E.D. Power Supply (Analog only), 115/230 V.AC
-	51-06026	Power Supply Mounting Bracket (Rack)
-	51-06030	Power Supply Mounting Bracket (Console)

Field Retrofit Kits for Converting Direct-Scan 5 Star Soundheads

51-98261	Analog Only
51-98258	Analog; Digital Convertible
51-98300	Analog & Digital (SR•D)

REVERSE SCAN COMPONENTS

Infrared Analog L.E.D. with
Quartz Lamp Digital
(1995 - 1997 Production)

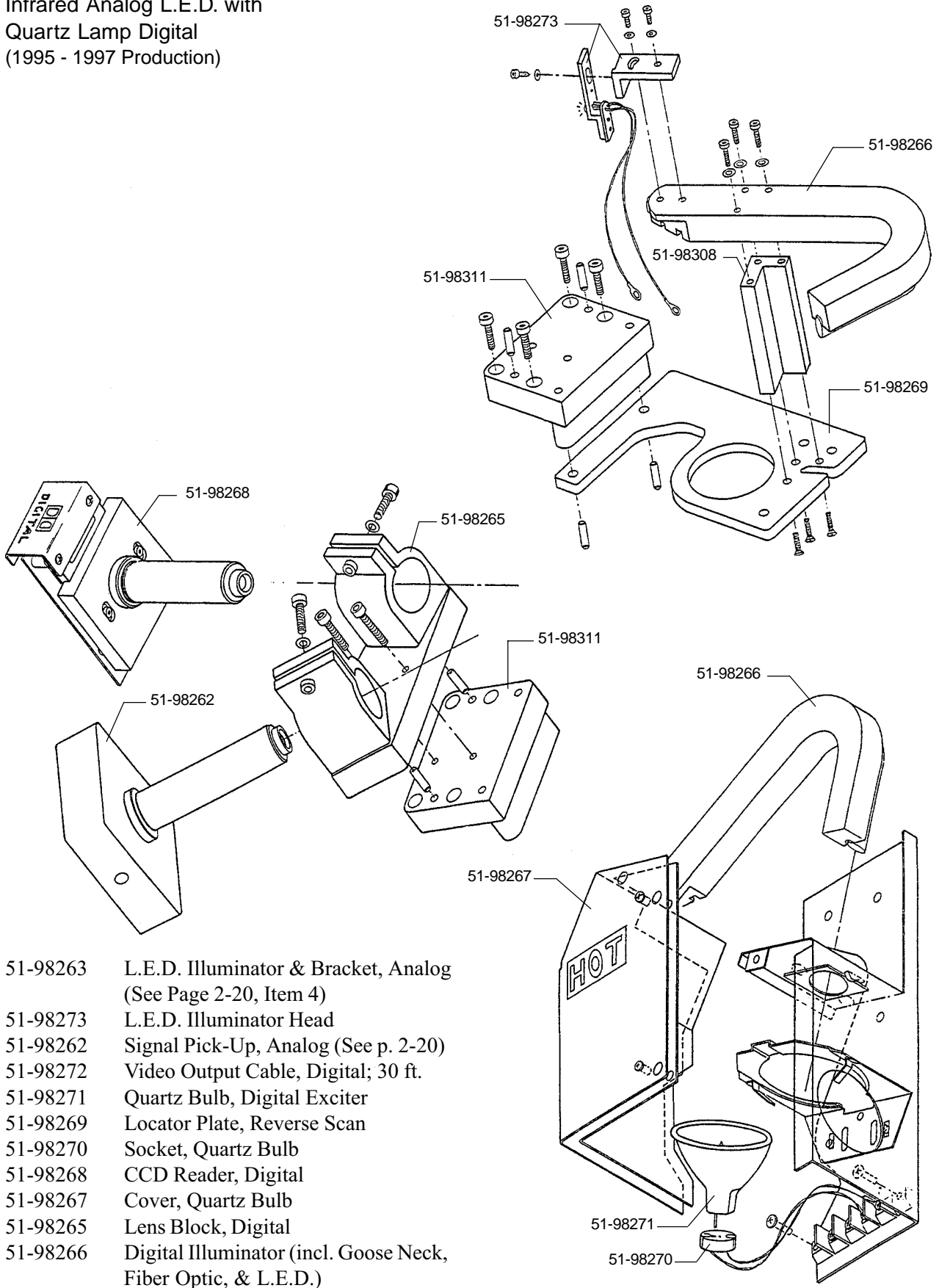

- 51-98263 L.E.D. Illuminator & Bracket, Analog
(See Page 2-20, Item 4)
- 51-98273 L.E.D. Illuminator Head
- 51-98262 Signal Pick-Up, Analog (See p. 2-20)
- 51-98272 Video Output Cable, Digital; 30 ft.
- 51-98271 Quartz Bulb, Digital Exciter
- 51-98269 Locator Plate, Reverse Scan
- 51-98270 Socket, Quartz Bulb
- 51-98268 CCD Reader, Digital
- 51-98267 Cover, Quartz Bulb
- 51-98265 Lens Block, Digital
- 51-98266 Digital Illuminator (incl. Goose Neck,
Fiber Optic, & L.E.D.)

REVERSE SCAN COMPONENTS
 Kelmar Reader ATD-1276 (optional)

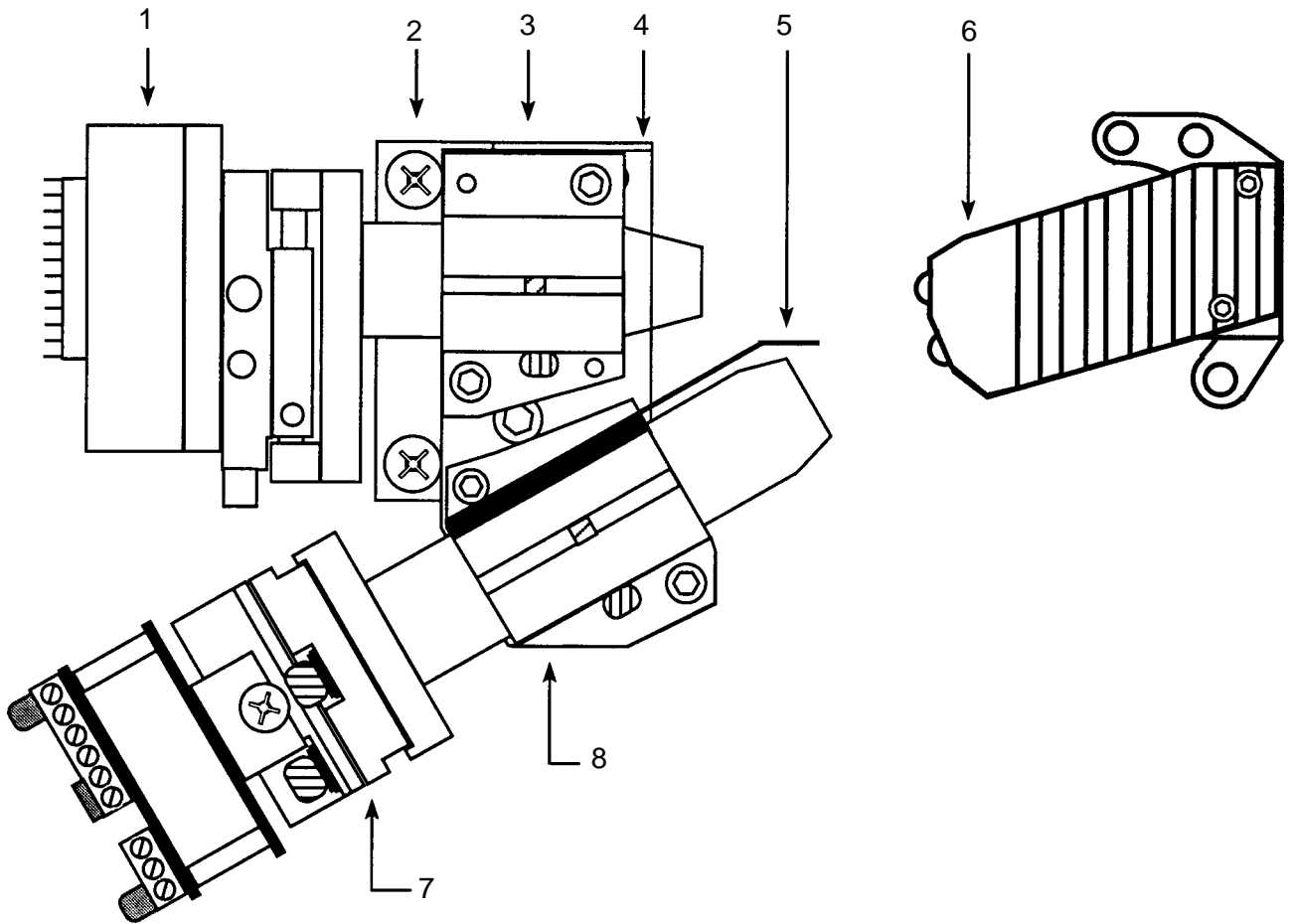

<u>Item</u>	<u>Part No.</u>	<u>Description</u>
1	54-68110	Digital Reader Assembly
2	54-68111	Mounting Base Plate
3	54-68112	Digital Reader Clamp Block
4	54-68113	Reader Mounting Plate
5	54-68114	Light Shield
6	54-68115	Dual L.E.D. Assembly
7	54-68116	Analog Reader Assembly
8	54-68117	Analog Reader Clamp Block

REVERSE SCAN COMPONENTS
 Kelmar Dual L.E.D. Reader (optional)

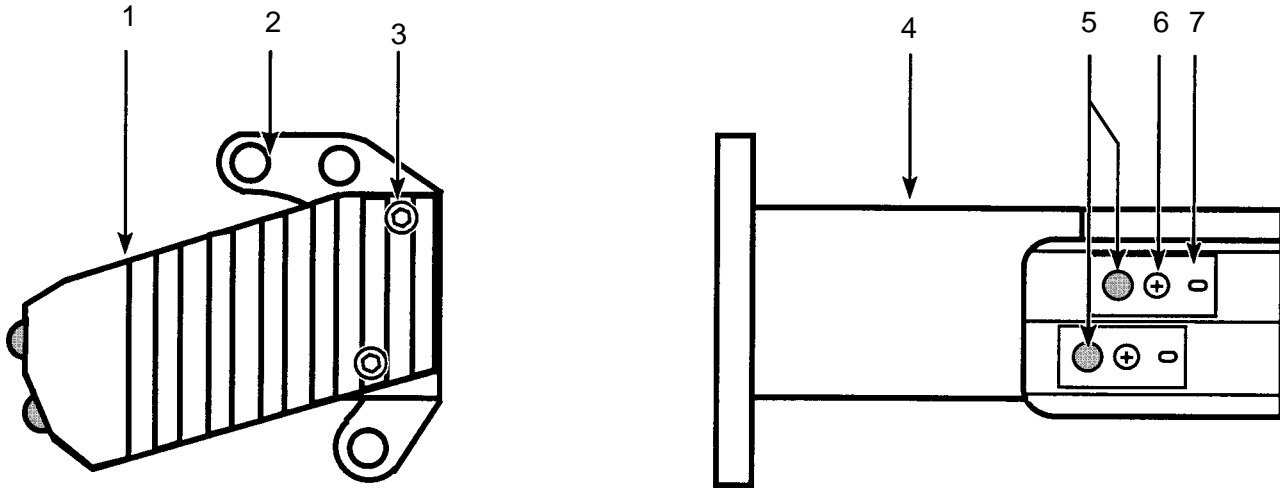

<u>Item</u>	<u>Part No.</u>	<u>Description</u>
1	54-68118	Arm
2	54-68119	Base
3	41-51392	Screw, 4-40 x 3/4" Socket Head
4	54-68121	Post
5	54-68122	L.E.D.
6	54-68123	Clamp Screw
7	54-68124	L.E.D. Clamp

REVERSE SCAN COMPONENTS
 Kelmar Digital Reader Assembly (optional)

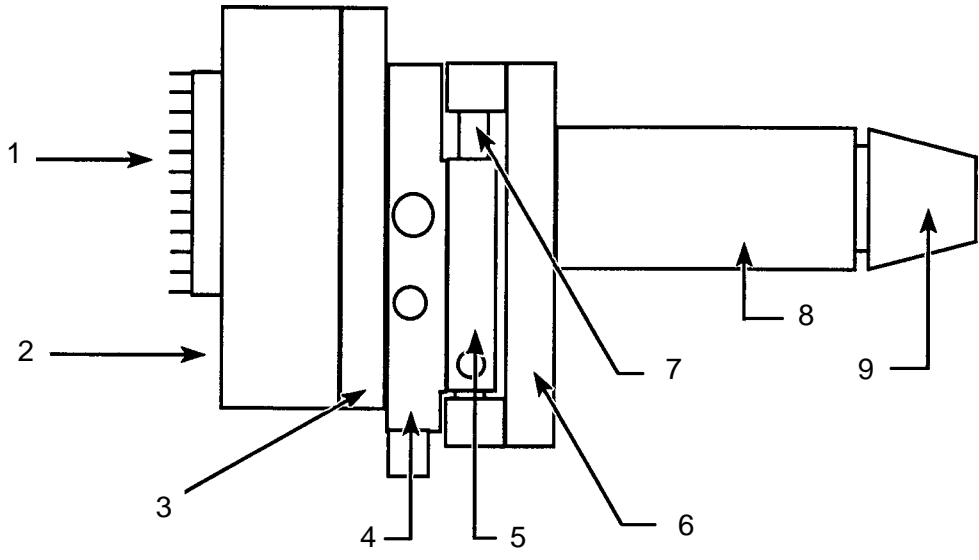

<u>Item</u>	<u>Part No.</u>	<u>Description</u>
1	54-68101	CCD Reader Board
2	54-68102	Cover, CCD Reader Board
3	54-68103	Base Plate, CCD Reader
4	54-68104	Vertical Plate
5	54-68105	Horizontal Plate
6	54-68106	Base Plate
7	54-68107	Horizontal Shaft Runner Shaft
8	54-68108	Lens Tube
9	54-68109	Lens & Carrier

REVERSE SCAN COMPONENTS
 Kelmar Analog Lens & Solar Cell (optional)

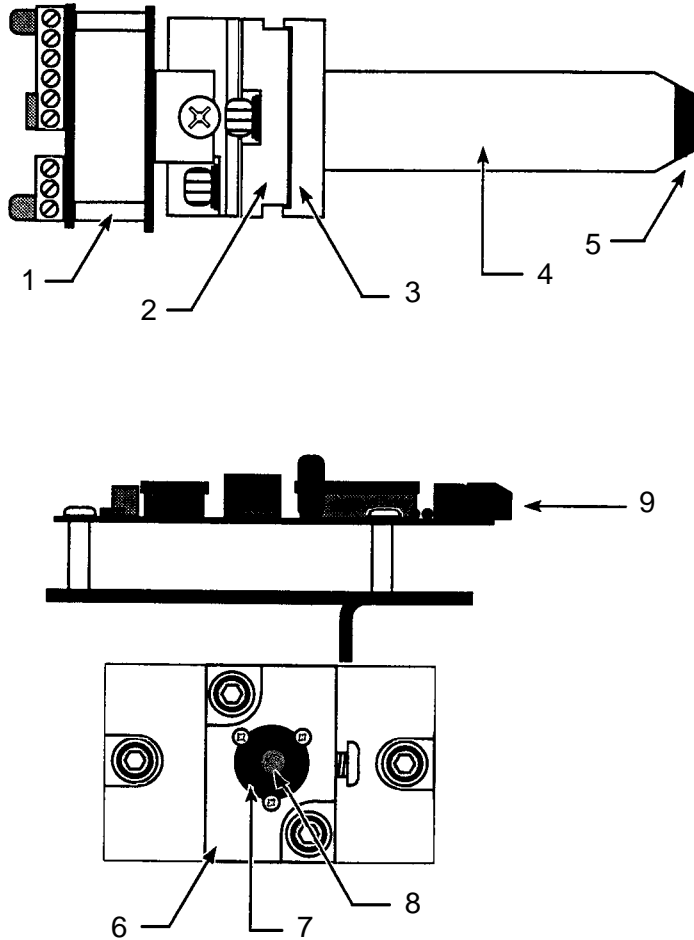

<u>Item</u>	<u>Part No.</u>	<u>Description</u>
1	54-68125	Mounting Plate, Pre-Amp Board
2	54-68126	Horizontal Slide
3	54-68127	Main Base Plate
4	54-68128	Lens Tube
5	54-68129	Lens
6	54-68130	Vertical Slide
7	54-68131	Solar Cell Retainer
8	54-68132	Solar Cell, with Mask
9	54-68133	Solar Cell Pre-Amp

SIMPLEX 5 STAR SOUNDHEAD PULLEYS

<u>Motor rpm</u>	<u>Motor Pulley</u>	<u>Drive Belt</u>	<u>Soundhead Pulley</u>
1800	52-00120	51-05014	52-20268
1750	52-00120	51-05014	52-00071
1500	52-00120	51-05015	52-20550
1500	52-40127	51-05016	52-20558
1200	52-40127	51-05014	52-20147
1000	52-20559	51-05016	52-20558

52-00120 = 18 Tooth

52-40127 = 24 Tooth

52-20559 = 36 Tooth

52-20600 = 50 Tooth

52-20513 = 70 Tooth

52-20550 = 75 Tooth

52-20147 = 80 Tooth

52-00071 = 89 Tooth

52-20268 = 90 Tooth

52-20558 = 100 Tooth