

# CAT. NO. 702

## DOLBY DIGITAL SOUNDHEAD

The Dolby® Cat. No. 702 Digital Soundhead is a penthouse-type reader that bolts directly to many current and older projectors, enabling playback of Dolby Digital and Dolby Digital Surround EX™ soundtracks.

Designed for high performance and long-term durability, the Cat. No. 702 is a reference standard for Dolby Digital soundtrack reproduction. To read the Dolby Digital track on 35 mm Dolby Digital release prints, the Cat. No. 702 uses a newly designed, more efficient CCD board and lens, an LED level indicator and adjustment, an integral power supply that requires no AC connection, and the latest in LED technology. The resulting signal is fed to the cinema's Dolby Digital processor or decoder.

To ensure smooth film motion, the Cat. No. 702 features an easily threaded Davis tight loop configuration with twin tension arms for superior film guidance.

With benefits that include high sound quality, on-film soundtrack placement, and ease of print manufacture, Dolby Digital is the standard for multichannel sound around the world. The Cat. No. 702 soundhead facilitates upgrading cinema systems to take full advantage of Dolby Digital, including Dolby Digital Surround EX with its third, rear surround channel.



**DD Dolby®**

Dolby Laboratories, Inc. 100 Potrero Avenue, San Francisco, CA 94103-4813 Telephone 415-558-0200 Fax 415-863-1373

Wootton Bassett, Wiltshire SN4 8QJ, England Telephone (44) 1793-842100 Fax (44) 1793-842101

For additional information, contact [salesadmin@dolby.com](mailto:salesadmin@dolby.com) [www.dolby.com](http://www.dolby.com)

# CAT. NO. 702

## DOLBY DIGITAL SOUNDHEAD

### Cat. No. 702 Specifications

#### Construction

Die-cast aluminum with matte black finish

#### Mounting

The soundhead mounts to the following projectors directly:

Ballantyne Pro 35

Century 35

Century JJ (early versions may require an adapter)

Christie P35

Simplex 35/70 and 35

Cinemeccanica V4, V5, V8, and V9

Note: A Cat. No. 690 Adapter is required to reinstall the Cinemeccanica V5 or V8 upper reel arm on the top of the Cat. No. 702 Digital Soundhead Adapter mounting plates are available for the following projectors:

Norelco AA-II/Philips DP70: Dolby Cat. No. 695

Kinoton DP75, FP20, and FP30: Dolby Cat.

No. 696

#### Signal Connections

A shielded, computer-grade video cable connects the soundhead to the cinema processor; the soundhead ships with a 10-meter (32.8 foot) cable with a 12-pin female connector for connection to the Cat. No. 702 and a 25-pin male D-connector for the processor

#### Internal Controls

The soundhead includes a control for adjusting the drive current to the LED

#### Accessories

Roller assemblies (35 mm and a combination 35/70 mm) are available for threading film along an optional bypass path

Long video cables for connecting the soundhead are also available:

15-meter (49-foot) cable: Part No. 83237

30-meter (98 foot) cable: Part No. 83142

#### Dimensions and Weight

150 × 175 × 275 mm (5.9 × 6.9 × 10.8 inches)

Net: 5 kg (11 lb)

#### Environmental Conditions

Operating: 0° to 40° C (32° to 104° F)

Non-operating (Storage): 0 to 85° C (32° to 185° F)

Humidity: 20 to 80% relative humidity, noncondensing

#### Regulatory Notices

North America: This unit complies with the limits for a Class A digital device, pursuant to Part 15 of the FCC rules, and Industry Canada ICES-003 specifications. Europe: This unit complies with the requirements of EMC Directive 89/336/EEC and carries the CE marking accordingly.

#### Warranty

One-year limited, parts and labor; see disclaimer below

Specifications subject to change without notice.

Dolby and the double-D symbol are registered trademarks of Dolby Laboratories. Surround EX is a trademark of Dolby Laboratories. All other trademarks remain the property of their respective owners.

© 2002 Dolby Laboratories, Inc. All rights reserved. S02/14456

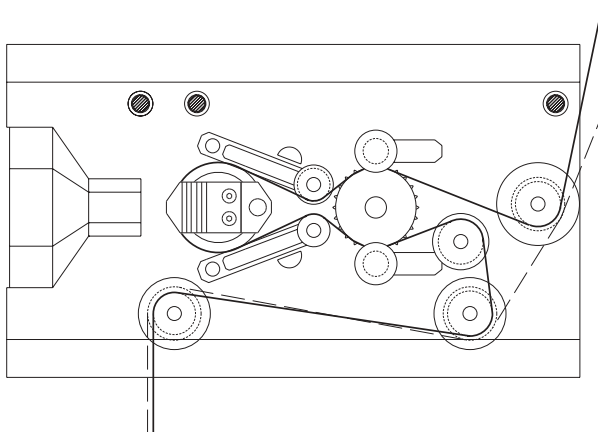

#### DISCLAIMER OF WARRANTIES:

Equipment manufactured by Dolby Laboratories is warranted against defects in materials and workmanship for a period of one year from the date of purchase. There are no other express or implied warranties and no warranty of merchantability or fitness for a particular purpose.

#### LIMITATION OF LIABILITY:

It is understood and agreed that Dolby Laboratories' liability, whether in contract, in tort, under any warranty, in negligence, or otherwise, shall not exceed the cost of repair or replacement of the defective components and under no circumstances shall Dolby Laboratories be liable for incidental, special, direct, indirect, or consequential damages (including but not limited to damage to software or recorded audio or visual material), or loss of use, revenue, or profit, even if Dolby Laboratories or its agents have been advised, orally or in writing, of the possibility of such damages.