

SLC Xenon Console



Comes standard with manual bulb adjustments offering a choice of the following options:

- Patented automatic bulb focus
- Motorized 3-Axis Bulb Adjustment (MOT)
- Motorized bulb focus only
- 57" sound rack, mounted
- IR filters for 2-7K systems
- Floor mount sound racks
- External exhaust blower

APPLICATIONS

- Cinema/exhibition

SLC Xenon Console Maximizes Output from Xenon Lamps

The SLC Console, designed with state of the art innovations and features, has become the standard in the industry. The SLC is engineered to provide high quality, low cost and reliable performance, time and again.

The SLC is designed around a computer generated dichroic coated reflector, which will optimize the output of the Xenon bulb. The SLC Console provides the brightest and most uniform light distribution available today. The revolutionary forced air plenum pressurizes the reflector housing. Increased air pressure is forced out over the Xenon lamp and reflector, allowing for more uniform surface cooling, which extends the lamp life.

Incorporated in the SLC are features not found in any other Xenon system. The patented 3-axis bulb adjustment mechanism operates on special AC gear motors, allowing the operator to precisely align the bulb for maximum output. Once aligned, the motors hold the bulb firmly in place, preventing any vibration or movement.

The SLC is designed as a sturdy platform with a rigid steel reinforced framework that will accommodate the heaviest of projectors. Easy-open lift-off doors provide quick and convenient access to the console whenever maintenance is required.

Christie's SLC Console offers space for standard rack mounting of automations, audio gear, etc. Additionally, the SLC can be fitted with a 19" sound rack mounted to the console and providing 57" of space for a full complement of stereo components.

The SLC Console will provide many years of high performance and service, while minimizing installation and operating expenses.

SLC Xenon Console • Specifications

Weight and Dimensions

SLC 20/30

- 590 lbs
- 42" L x 71" H x 24" W

SLC 40/45/70

- 660 lbs
- 42" L x 71" H x 24" W

Power Requirements

SLC 20/30

- 208/230 VAC
- 60Hz
- 20 amp
- Current range: 65-105

SLC 40

- 208/230 VAC
- 60Hz
- 27 amp
- Current range: 80-150

SLC45/70

- 208/230 VAC
- 60Hz
- 40 amp
- Current range: 110-205

Also Available As:

- 380/415 VAC, 50/60Hz
- 200 VAC, 50/60Hz

Specify when ordering

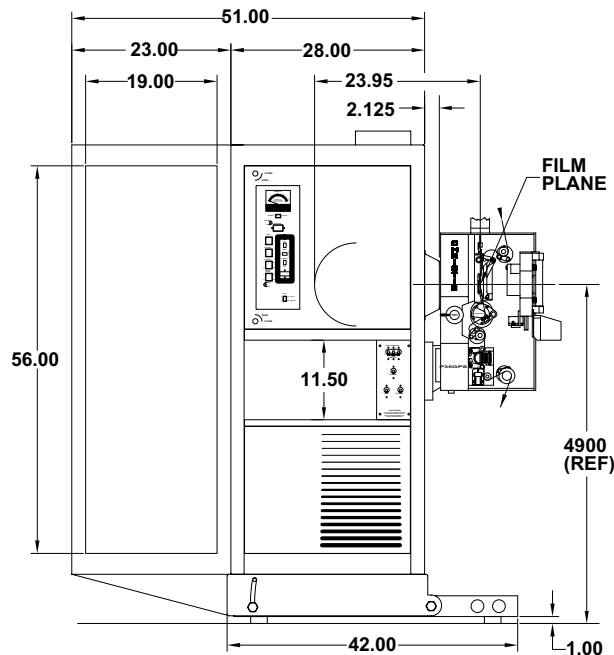

Shown with optional soundtrack attached.

Head Offices

USA
10550 Camden Drive
Cypress, CA 90630
PH: 714-236-8610
FX: 714-503-3385
Toll free: (800) 407-7727 (NA only)
sales-us@christiedigital.com

CANADA
809 Wellington Street North
Kitchener, Ontario N2G 4Y7
PH: 519-744-8005
FX: 519-749-3136
Toll free: (800) 265-2171 (NA only)
sales-canada@christiedigital.com

Branch Offices

UNITED KINGDOM
PH: +44 118 977 8000
FX: +44 118 977 8100
sales-europe@christiedigital.com

SINGAPORE
PH: +65 6877-8737
FX: +65 6877-8747
sales-singapore@christiedigital.com

FRANCE
PH: +33 (0) 1 47 48 28 07
FX: +33 (0) 1 47 48 26 06
Mobile: +33 (0) 6 76 47 43 62
sales-france@christiedigital.com

GERMANY
PH: +49 2161 664540
FX: +49 2161 664546
sales-europe@christiedigital.com

CHINA
PH: +86 21 6278 7708
FX: +86 21 6278 7707
sales-china@christiedigital.com

Designed under ISO 9001

FEATURES



- 3-axis bulb adjustment mechanism for precision alignment.



- Adjustable output rating, controlled current power supply.



- Easy operation push button control, with digital timer and ammeter.



Due to constant research, specifications are subject to change without notice.